

OKI electronic components

KGF1146

Small-Signal Amplifier

GENERAL DESCRIPTION

The KGF1146 is a two-stage small-signal UHF-band amplifier that features low current operation, high output power, and high isolation. The KGF1146 specifications are guaranteed to a fixed matching circuit for 5 V and 850 MHz; external impedance-matching circuits are also required. Because of the high isolation, the KGF1146 is an ideal part for a VCO-buffer amplifiers and an intermediate-stage amplifier for personal handy phones, such as cellular phones.

FEATURES

- Low current operation: 2.5 mA (max.)
- High output power: 1.5 dBm (min.)
- High isolation: -40 dB
- Self-bias circuit configuration with built-in source capacitor
- Package: 4PSOP

PACKAGE DIMENSIONS

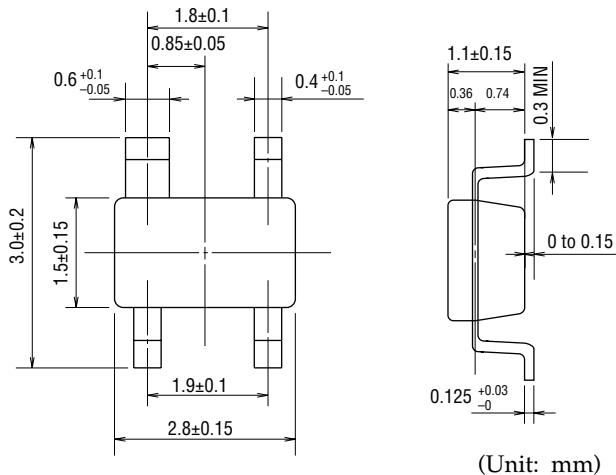

Package material	Epoxy resin
Lead frame material	42 alloy
Pin treatment	Solder plating
Solder plate thickness	5 μm or more

MARKING

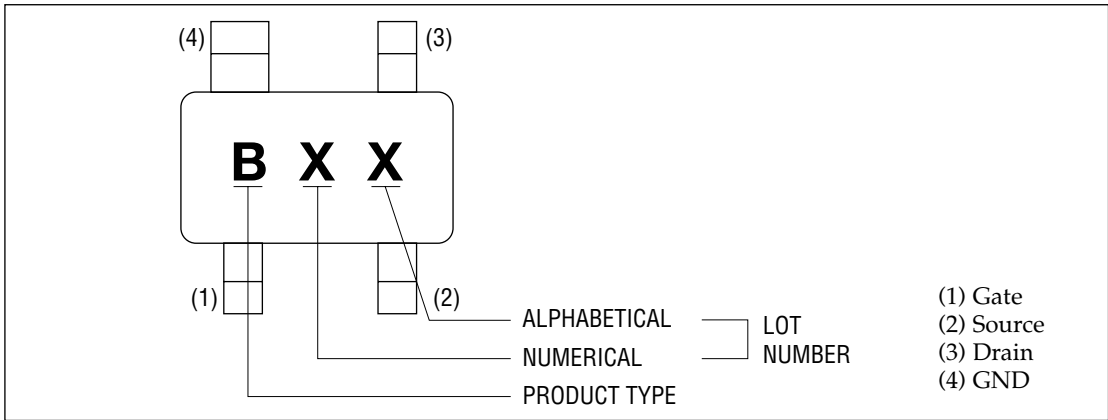

CIRCUIT

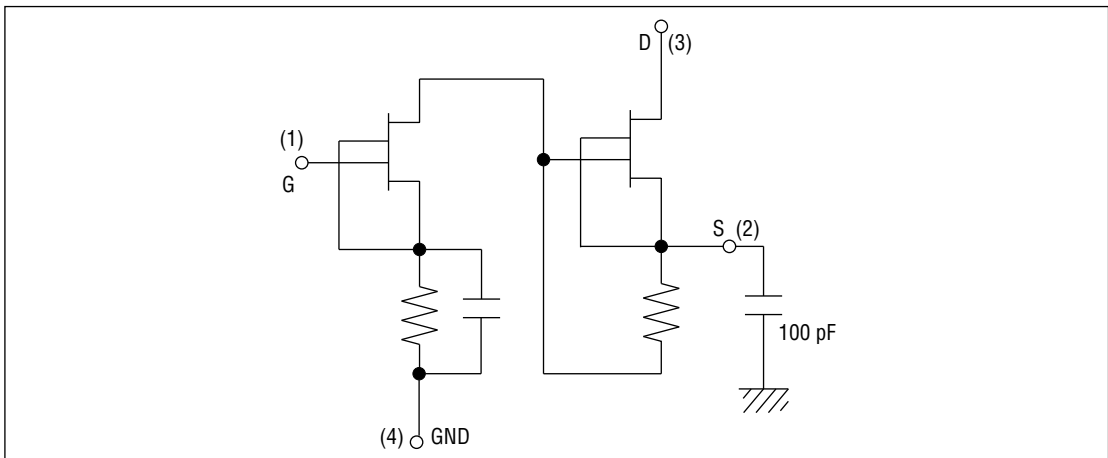

APPLICATION EXAMPLE FOR PORTABLE PHONES

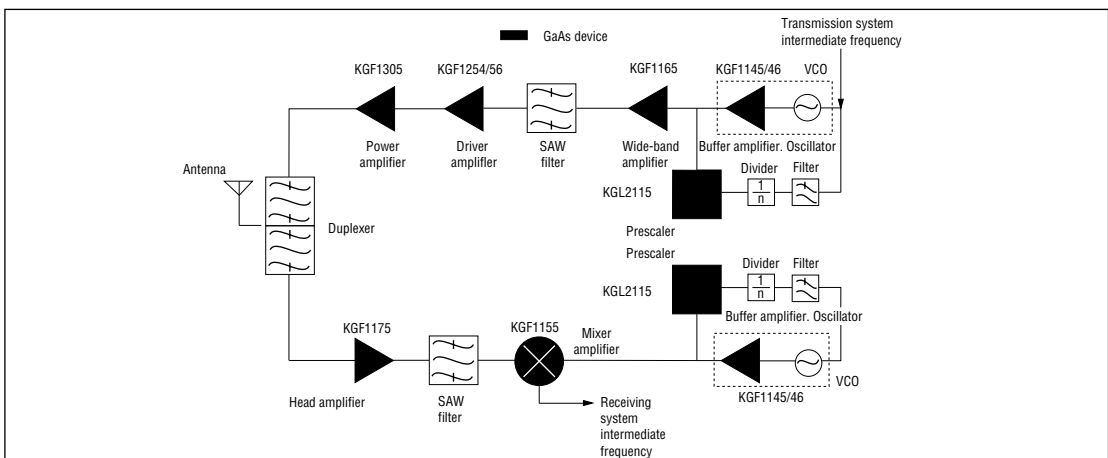

ABSOLUTE MAXIMUM RATINGS

(Ta = 25°C)

Item	Symbol	Unit	Min.	Max.
Drain-source voltage	V _{DS}	V	—	6
Gate-source voltage	V _{GS}	V	-3	0.4
Drain current	I _{DS}	mA	—	60
Total power dissipation	P _{tot}	mW	—	200
Channel temperature	T _{ch}	°C	—	150
Storage temperature	T _{stg}	°C	-45	125

ELECTRICAL CHARACTERISTICS

(Ta = 25°C)

Item	Symbol	Condition	Unit	Min.	Max.
Gate-source leakage current	I _{GSS}	V _{GS} = -3 V	μA	—	12
Gate-drain leakage current	I _{GDO}	V _{GDO} = -6 V	μA	—	60
Drain-source leakage current	I _{DS(off)}	V _{DS} = 3 V, V _{GS} = -2.0 V	μA	—	120
Drain current	I _{DSS}	V _{DS} = 3 V, V _{GS} = 0 V	mA	15	—
Operating current	I _D	(*1), P _{IN} = -10 dBm	mA	—	2.5
Gate-source cut-off voltage	V _{GS(off)}	V _{DS} = 3 V, I _{DS} = 120 μA	V	-1.5	-0.5
Transconductance	g _m	V _{DS} = 3 V, I _{DS} = 2.0 mA	mS	8	—
Output power	P _O	(*1), P _{IN} = -10 dBm	dBm	1.5	—
Isolation	ISO	(*1), P _{IN} = -10 dBm	dB	40	—

*1 Self-bias condition: V_{DD} = 5.0 ± 0.25 V, V_G = 0 V, f = 850 MHz

RF CHARACTERISTICS

P_o vs. P_{IN}

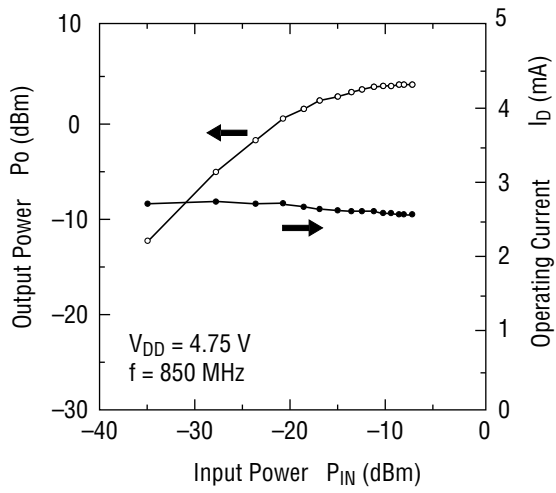

Typical S Parameters

 $V_{DD} = 5\text{ V}$, $I_D = 1.85\text{ mA}$

Freq(MHz)	MAG(S ₁₁)	ANG(S ₁₁)	MAG(S ₂₁)	ANG(S ₂₁)	MAG(S ₁₂)	ANG(S ₁₂)	MAG(S ₂₂)	ANG(S ₂₂)
500.0	1.016	-13.78	3.144	-53.83	0.002	91.21	0.954	-7.09
600.0	1.008	-16.42	3.184	-65.20	0.002	72.13	0.954	-8.39
700.0	1.002	-19.14	3.091	-76.19	0.001	88.37	0.954	-9.92
800.0	0.995	-21.80	3.060	-84.59	0.002	87.52	0.952	-11.21
900.0	0.988	-24.38	2.952	-92.88	0.003	75.89	0.950	-12.84
1000.0	0.981	-26.95	2.961	-98.49	0.002	69.05	0.948	-14.07
1100.0	0.973	-29.64	2.741	-105.75	0.001	51.70	0.952	-15.34
1200.0	0.963	-32.24	2.687	-111.43	0.002	89.09	0.944	-16.82
1300.0	0.956	-34.90	2.557	-117.29	0.001	31.04	0.945	-18.09
1400.0	0.945	-37.58	2.481	-122.72	0.001	96.43	0.941	-19.74
1500.0	0.938	-40.39	2.316	-129.37	0.001	138.33	0.941	-20.90
1600.0	0.929	-42.98	2.187	-134.82	0.001	124.06	0.937	-22.03
1700.0	0.918	-46.03	2.009	-140.24	0.002	-115.76	0.941	-23.52
1800.0	0.906	-48.76	1.872	-151.35	0.001	-129.25	0.932	-24.82
1900.0	0.897	-51.64	1.775	-155.91	0.003	-128.46	0.934	-26.27
2000.0	0.880	-54.61	1.710	-161.08	0.003	-121.98	0.929	-27.28
2100.0	0.868	-57.75	1.650	-166.40	0.005	-139.31	0.926	-28.67
2200.0	0.855	-60.87	1.562	-171.49	0.007	-126.58	0.927	-29.86
2300.0	0.847	-63.86	1.499	-176.27	0.008	-127.50	0.923	-30.90
2400.0	0.830	-66.88	1.470	179.50	0.009	-139.94	0.924	-32.30
2500.0	0.819	-69.77	1.413	176.86	0.013	-129.23	0.920	-33.42
2600.0	0.804	-72.90	1.364	174.40	0.014	-134.15	0.919	-34.91
2700.0	0.792	-76.11	1.337	169.45	0.016	-136.16	0.914	-35.62
2800.0	0.778	-79.41	1.304	164.51	0.019	-140.71	0.916	-37.07
2900.0	0.770	-82.77	1.287	159.93	0.024	-134.62	0.914	-37.84
3000.0	0.754	-85.91	1.238	155.02	0.028	-137.56	0.916	-38.89

Typical S Parameters

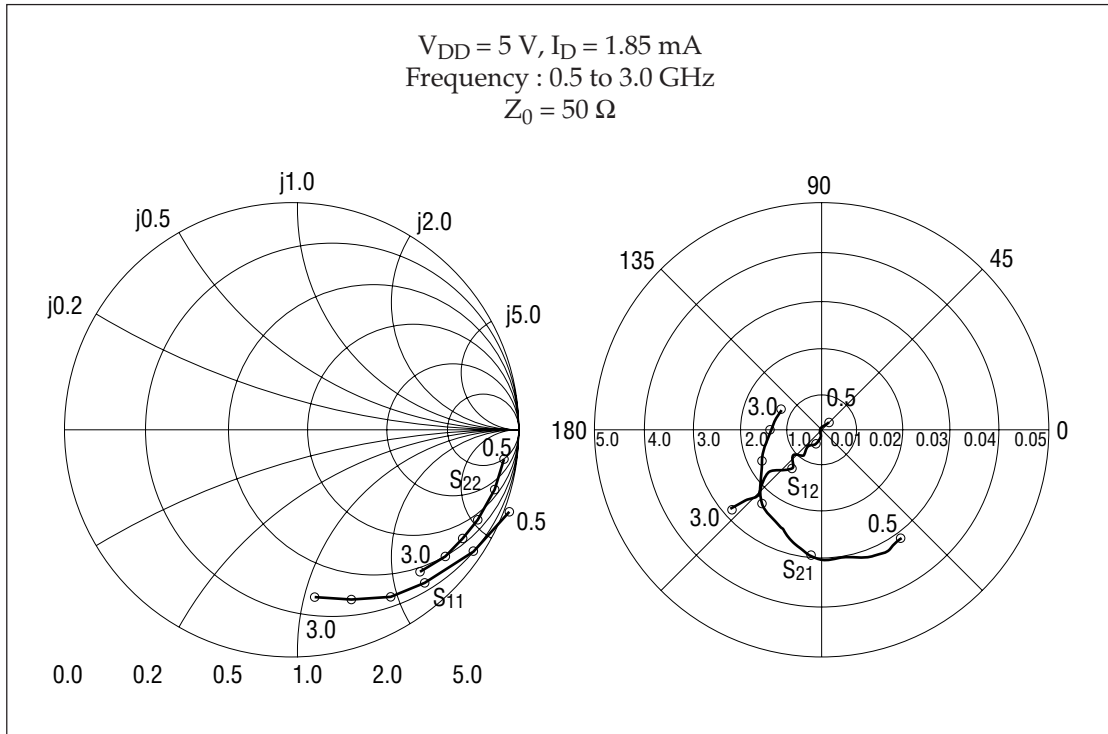

Test Circuit

