

# OKI electronic components

## KGF1283

### Power FET (Plastic Package Type)

#### GENERAL DESCRIPTION

The KGF1283, housed in a SOT-89 type plastic-mold package, is a discrete UHF-band power FET that features high efficiency, high output power, and high gain. The KGF1283 specifications are guaranteed to a fixed matching circuit for 5.8 V and 850 MHz; external impedance-matching circuits are also required. Because of its high efficiency, high output power (more than 26.5 dBm), high gain, and plastic package, the KGF1283 is ideal as a transmitter-driver amplifier for personal handy phones.

#### FEATURES

- High output power: 26.5 dBm (min.)
- High efficiency: 60% (typ.)
- High linear gain: 17 dB (typ.)
- Package: 3PMMP (SOT-89 type)

#### PACKAGE DIMENSIONS

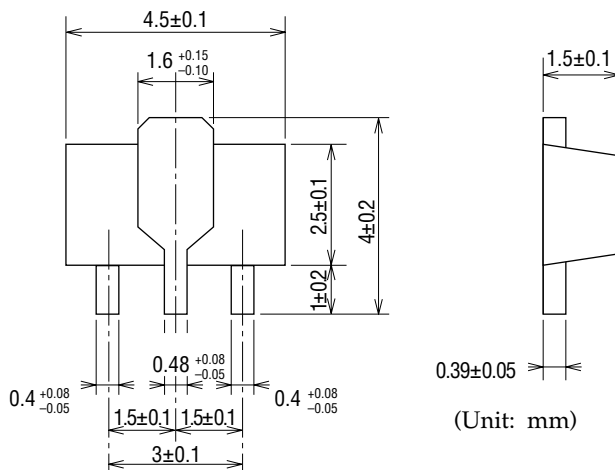

Package material	Epoxy resin
Lead frame material	Cu
Pin treatment	Solder plating
Solder plate thickness	5 $\mu$ m or more

## MARKING

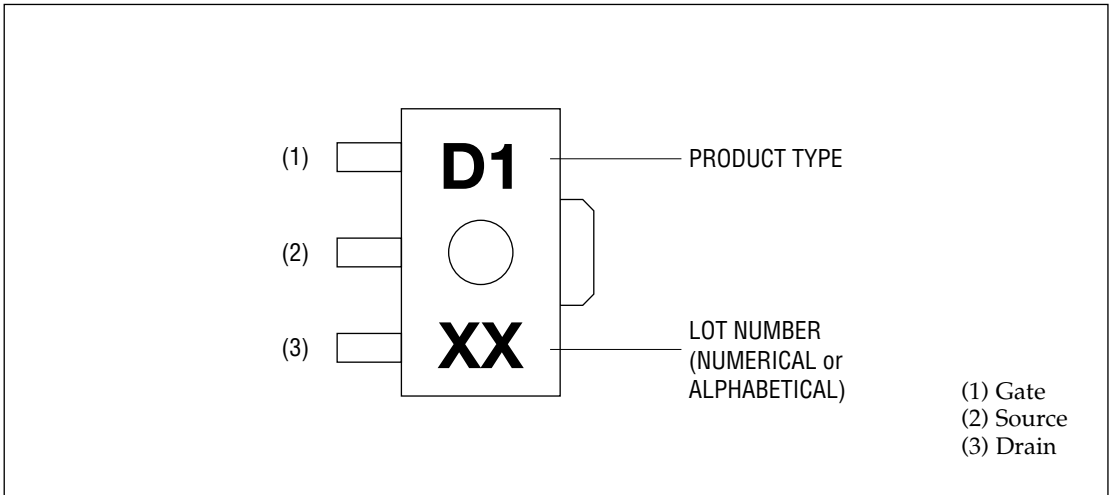

## CIRCUIT

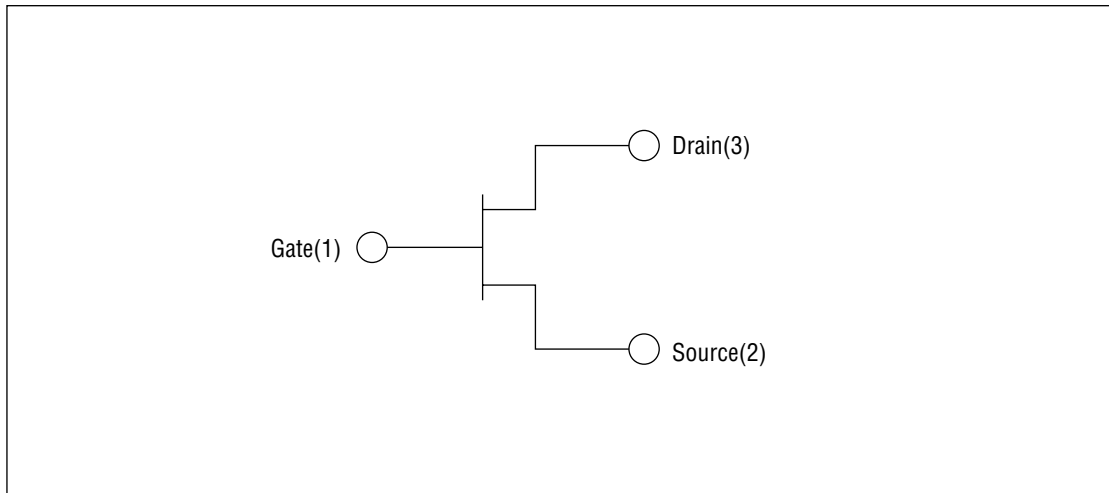

**ABSOLUTE MAXIMUM RATINGS**

Item	Symbol	Condition	Unit	Min.	Max.
Drain-source voltage	$V_{DS}$	$T_a = 25^\circ\text{C}$	V	—	10
Gate-source voltage	$V_{GS}$	$T_a = 25^\circ\text{C}$	V	-6.0	0.4
Drain current	$I_{DS}$	$T_a = 25^\circ\text{C}$	A	—	0.8
Total power dissipation	$P_{tot}$	$T_a = T_c = 25^\circ\text{C}$	W	—	2.5
Channel temperature	$T_{ch}$	—	$^\circ\text{C}$	—	150
Storage temperature	$T_{stg}$	—	$^\circ\text{C}$	-45	125

**ELECTRICAL CHARACTERISTICS**

(Ta = 25°C)

Item	Symbol	Condition	Unit	Min.	Typ.	Max.
Gate-source leakage current	$I_{GSS}$	$V_{GS} = -6\text{ V}$	$\mu\text{A}$	—	—	50
Gate-drain leakage current	$I_{GDO}$	$V_{GD} = -16\text{ V}$	$\mu\text{A}$	—	—	150
Drain-source leakage current	$I_{DS(off)}$	$V_{DS} = 10\text{ V}, V_{GS} = -6\text{ V}$	$\mu\text{A}$	—	—	500
Drain current	$I_{DSS}$	$V_{DS} = 1.5\text{ V}, V_{GS} = 0\text{ V}$	mA	450	—	—
Gate-source cut-off voltage	$V_{GS(off)}$	$V_{DS} = 3\text{ V}, I_{DS} = 1.4\text{ mA}$	V	-3.0	—	-2.0
Output power	$P_O$	(*1), $P_{IN} = 15\text{ dBm}$	dBm	26.5	27.5	—
Drain efficiency	$\eta_D$	(*1), $P_{IN} = 15\text{ dBm}$	%	50	60	—
Linear gain	$G_{LIN}$	(*1), $P_{IN} = -5\text{ dBm}$	dB	—	17.0	—
Thermal resistance	$R_{th}$	Channel to case	$^\circ\text{C/W}$	—	35	—

\*1 Condition:  $f = 850\text{ MHz}$ ,  $V_{DS} = 5.8\text{ V}$ ,  $I_{DSQ} = 70\text{ mA}$

**RF CHARACTERISTICS**

**Matching conditions**

Gamma S (Source impedance) :  $12.35 + j40.57 (\Omega)$

Gamma L (Load impedance) :  $33.74 - j12.38 (\Omega)$

**Bias conditions**

$V_{DS}=5.8V, I_{DSQ}=70mA, f=850MHz$

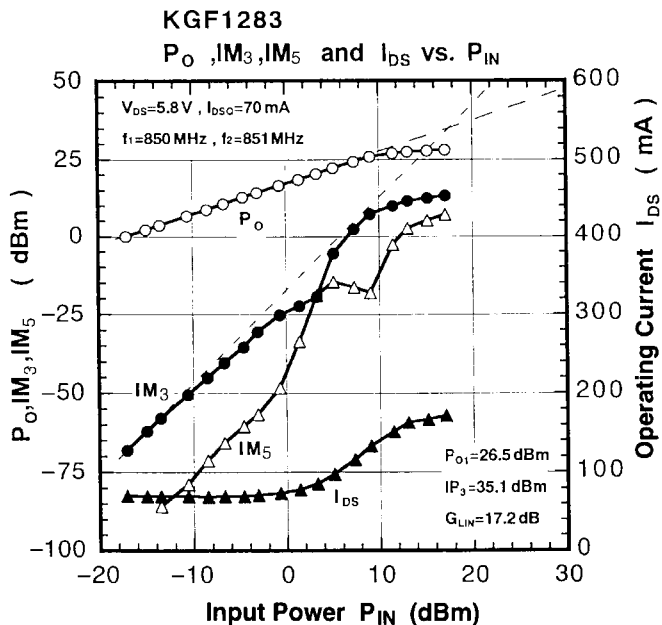
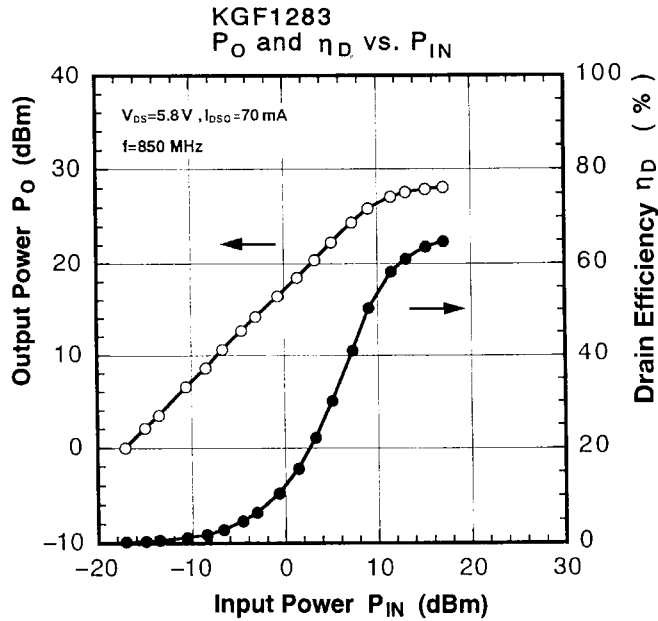

## Typical S Parameters

 $V_{DS} = 5.8 \text{ V}$ ,  $V_{GS} = -1.71 \text{ V}$ ,  $I_{DS} = 70 \text{ mA}$ 

Freq(MHz)	MAG(S <sub>11</sub> )	ANG(S <sub>11</sub> )	MAG(S <sub>21</sub> )	ANG(S <sub>21</sub> )	MAG(S <sub>12</sub> )	ANG(S <sub>12</sub> )	MAG(S <sub>22</sub> )	ANG(S <sub>22</sub> )
500.0	0.928	-75.55	6.052	128.22	0.041	53.15	0.216	-140.73
600.0	0.913	-86.65	5.575	121.14	0.045	48.09	0.238	-143.48
700.0	0.902	-96.40	5.152	114.59	0.049	43.65	0.256	-146.18
800.0	0.892	-105.12	4.788	108.53	0.053	40.10	0.271	-148.79
900.0	0.882	-112.97	4.454	103.41	0.056	36.55	0.283	-150.77
1000.0	0.876	-119.78	4.153	98.19	0.058	33.64	0.292	-153.12
1100.0	0.868	-126.19	3.895	93.46	0.060	31.03	0.299	-154.81
1200.0	0.861	-131.83	3.657	89.01	0.063	28.58	0.306	-156.91
1300.0	0.854	-137.11	3.464	84.72	0.064	26.57	0.311	-158.46
1400.0	0.846	-141.95	3.268	80.66	0.066	24.29	0.315	-159.96
1500.0	0.842	-146.44	3.107	76.72	0.067	22.61	0.318	-161.51
1600.0	0.835	-150.81	2.959	73.04	0.069	20.63	0.320	-163.03
1700.0	0.832	-155.00	2.816	69.53	0.070	19.19	0.323	-164.39
1800.0	0.819	-158.72	2.701	65.53	0.071	17.77	0.325	-165.64
1900.0	0.818	-162.30	2.571	62.36	0.073	15.95	0.324	-167.18
2000.0	0.808	-166.12	2.487	58.83	0.073	15.15	0.327	-168.37
2100.0	0.803	-169.41	2.375	55.18	0.075	13.37	0.326	-169.82
2200.0	0.795	-172.93	2.297	52.11	0.076	12.15	0.328	-171.17
2300.0	0.786	-176.05	2.200	48.43	0.077	10.98	0.327	-172.30
2400.0	0.781	-179.23	2.119	45.83	0.078	9.29	0.328	-173.76
2500.0	0.773	177.57	2.061	42.29	0.079	8.86	0.328	-175.26
2600.0	0.766	174.58	1.982	39.28	0.080	7.26	0.327	-176.65
2700.0	0.760	171.51	1.924	36.07	0.082	5.97	0.326	-177.97
2800.0	0.751	168.56	1.861	32.88	0.082	4.70	0.327	-179.20
2900.0	0.745	165.87	1.785	30.00	0.084	2.97	0.328	179.36
3000.0	0.742	162.94	1.742	27.08	0.084	2.19	0.329	177.71

### Typical S Parameters

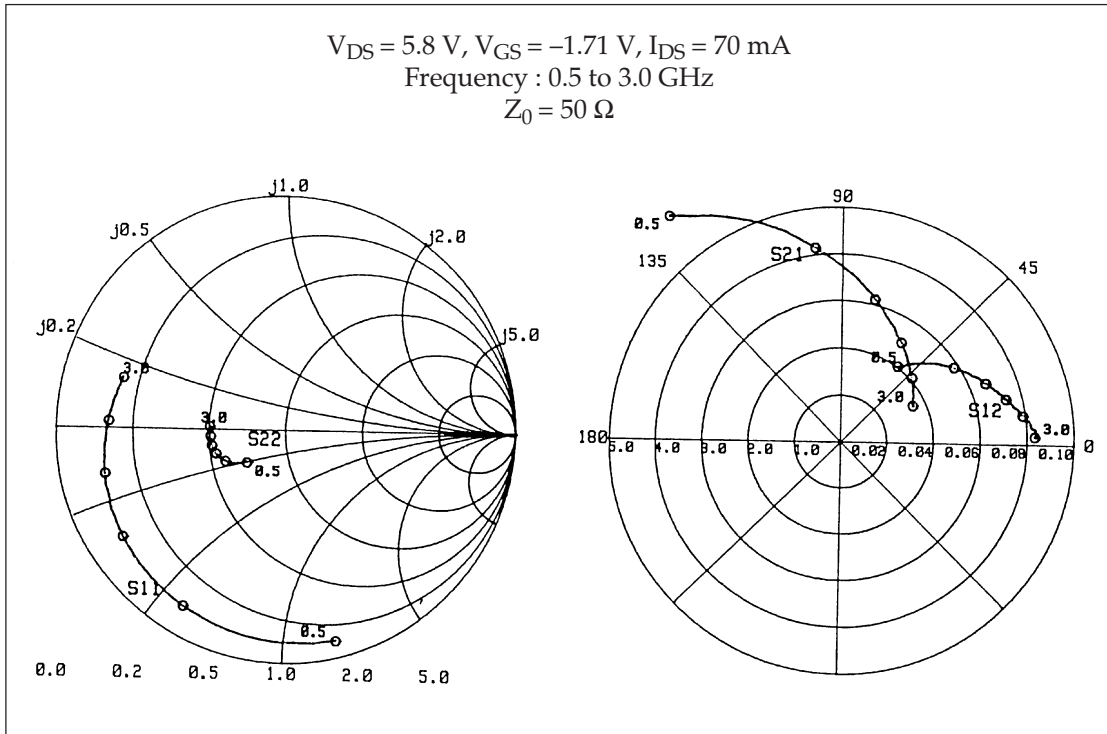

**Test Circuit and Bias Configuration for KGF1283 at 850 MHz**

