MSC1951-01

7-Segment × 16-Digit or 16-Segment × 6-Bargraph display Controller/Driver

GENERAL DESCRIPTION

MSC1951-01 is a Bi-CMOS bargraph and alphanumeric display controller designed to interface with either vacuum fluorescent display.

MSC1951-01 can drive displays with up to 16 figures with either 16 segment bargraph or seven-segment type code plus a decimal point and comma tail.

MSC1951-01 adopts a serial interface system, which allows data transfer from the microcomputer only by two signal lines of SCLK and DATA.

FEATURES

- Can display up to 16 digits of 7-segment type character with comma/point or of 16-segment type bargraph.
- The number of display digits is programmable within 16.
- The brightness adjustment is programmable by 1/32 step.
- The display contents can be changed at any digit.
- Built-in PLA can display alphanumeric characters, e.g., 0 to 9 A, C, E, F, P, L (capital letters), b, and d (small letters). In addition, 16-segment dot display and bar display are allowed.
- Instruction is executed by one byte.
- Driver output

Current	:	-20 mA max. (Digit)
		-10 mA (Segment), Plastic DIP
		- 5 mA (Segment), Plastic QFP
Withstand voltage	:	58 V max.
- Can be used for LED.
- Pin compatible with 10951 manufactured by Rockwell.
- Power supply voltage : 5V ± 10%
- Package options:

40-pin plastic DIP (DIP40-P-600-2.54)	(Product name : MSC1951-01RS)
44-pin plastic QFP (QFP44-P-910-0.80-K)	(Product name : MSC1951-01GS-K)

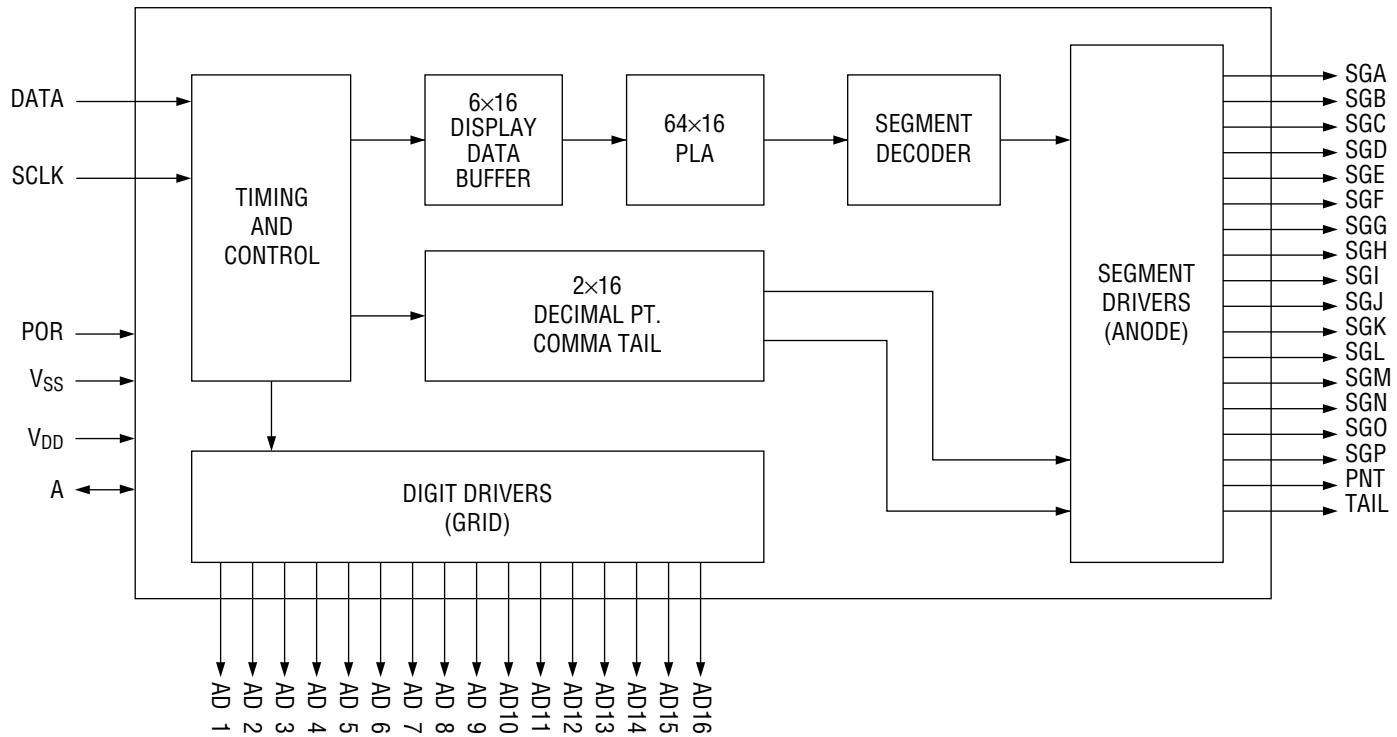

BLOCK DIAGRAM

INPUT AND OUTPUT CONFIGURATION

- Schematic Diagrams of Logic Portion Input Circuit

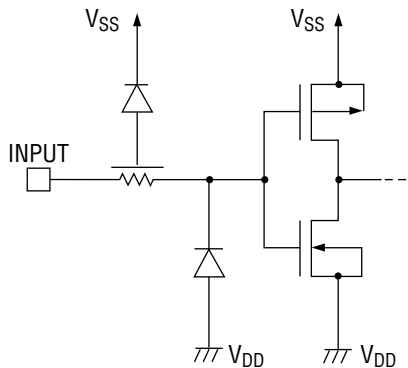

- Schematic Diagrams of Logic Portion Output Circuit

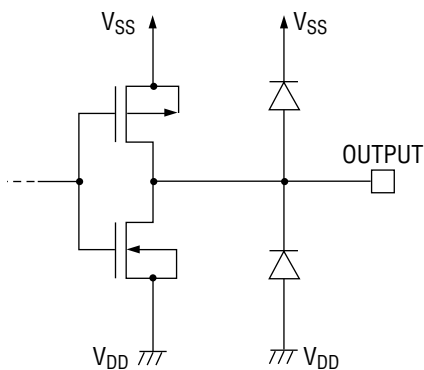

- Schematic Diagrams of Driver Output Circuit

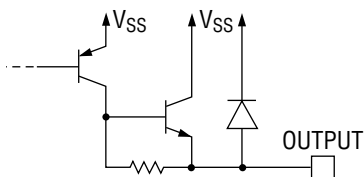

PIN CONFIGURATION (TOP VIEW)

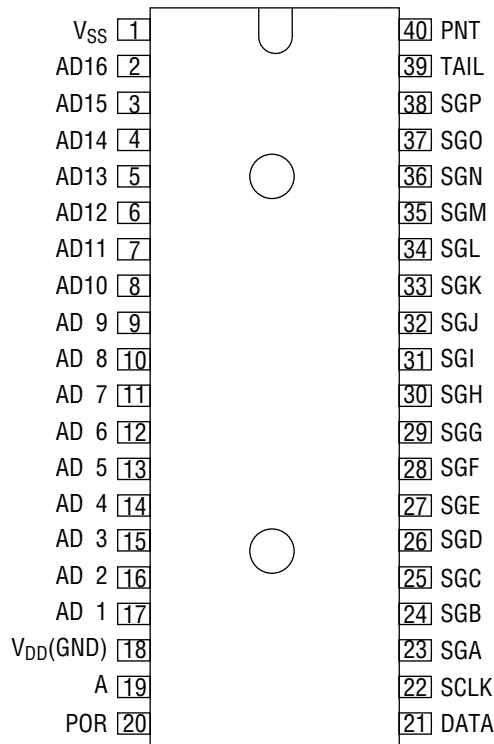

40-Pin Plastic DIP

Pin No.	Function
1	Power supply (5V)
2	Digit output pin 16
⋮	⋮
17	Digit output pin 1
18	GND
19	TEST pin
20	POWER-ON-RESET pin
21	Data input pin
22	Shift clock pin
23	Segment output pin A
⋮	⋮
38	Segment output pin P
39	TAIL output pin
40	POINT output pin

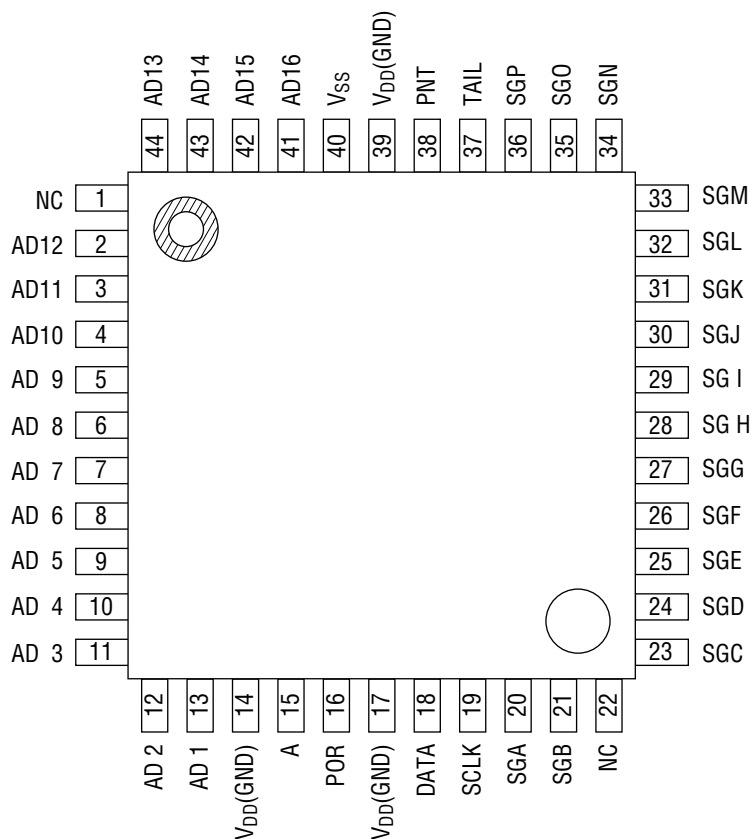

NC : No-connection pin

44-Pin Plastic QFP

Pin	Function	Pin	Function
1	No-connection pin	22	No-connection pin
2	Digit output pin 12	23	Segment output pin C
⋮	⋮	⋮	⋮
13	Digit output pin 1	36	Segment output pin P
14	GND	37	TAIL output pin
15	TEST pin	38	POINT output pin
16	POWER-ON-RESET pin	39	GND
17	GND	40	Power supply (5V)
18	Data input pin	41	Digit output pin 16
19	Shift clock pin	⋮	⋮
20	Segment output pin A	44	Digit output pin 13
21	Segment output pin B		

PIN DESCRIPTIONS

Symbol	Type	Description
V _{SS}	—	Power supply pin
V _{DD}	—	GND pin
DATA	I	Serial data Input of display data/control data Input from MSB
SCLK	I	Shift clock signal input of shift register Shifts data at the falling edge of SCLK
POR	I	Power-on-reset input. Input of "H" level into this pin with the power turned on initializes this IC. The internal state after the initialization is as follows: 1) AD1 to AD16, SGA to SGP, TAIL and PNT output are in the off state. 2) The duty cycle is set to "0". 3) The digit counter value is set to 16 digits. 4) The buffer pointer is set to AD1. 5) Pin "A" is in the output mode.
A	I/O	Usually used as an output mode, and outputs 1/5 of the internal oscillation frequency. In the test mode, operates as an input pin.
AD16 to AD1	O	Grid output pin The output configuration is an emitter follower.
SGA to SGP TAIL, PNT	O	Segment output pin The output configuration is an emitter follower.

ABSOLUTE MAXIMUM RATINGS

Parameter	Symbol	Rating	Unit		
Power Supply Voltage	V_{SS}	-0.3 to +6.5	V		
Input Voltage	V_{IN}	-0.3 to $V_{SS} + 0.3$	V		
Output Voltage	V_{SS}	$V_{SS} - 58$ to $V_{SS} + 0.3$	V		
Output Current	I_{LOAD}	Digit	-25	mA	
		Segment	DIP	-20	mA
			QFP	-10	mA
Storage Temperature	T_{STG}	-55 to 150	°C		

RECOMMENDED OPERATING CONDITIONS

Parameter	Symbol	Condition	Min.	Typ.	Max.	Unit
Power Supply Voltage	V_{SS}	—	4.5	—	5.5	V
High Level Input Voltage	V_{IH}	All inputs	3.6	—	5.5	V
Low Level Input Voltage	V_{IL}	All inputs	0.0	—	1.0	V
Clock Frequency	f_c	—	—	—	500	kHz
OSC Frequency	f_{OSC}	—	—	500	—	kHz
Frame Frequency	f_{FR}	—	—	195	—	Hz
Operating Temperature	T_{op}	—	-40	—	85	°C

ELECTRICAL CHARACTERISTICS

DC Characteristics

 $(V_{SS} = 5\text{ V} \pm 10\%, V_{GG} = -53\text{ V} \pm 0.5\text{ V}, T_a = -40\text{ to } +85^\circ\text{C})$

Parameter	Symbol	Condition		Min.	Max.	Unit	
High Level Input Voltage	V_{IH}	All inputs		3.6	5.5	V	
Low Level Input Voltage	V_{IL}	All inputs		0.0	1.0	V	
High Level Input Current	I_{IH}	$V_{IH} = V_{SS}$		-2.0	2.0	μA	
Low Level Input Current	I_{IL}	$V_{IL} = 0.0\text{ V}$		-2.0	2.0	μA	
High Level Output Voltage	V_{OH1}	Digit	$V_{SS} = 5\text{ V}$ $I_{LOAD} = -10\text{ mA}$	3.0	—	V	
	V_{OH2}	Segment	DIP	$V_{SS} = 5\text{ V}$ $I_{LOAD} = -10\text{ mA}$	2.5	—	V
			QFP	$V_{SS} = 5\text{ V}$ $I_{LOAD} = -5\text{ mA}$	2.5	—	V
Low Level Output Voltage	V_{OL}	"L" output current is determined by external pull-down resistor		—	$V_{GG} + 3.0$	V	
Output Leakage Current	I_{OUT}	$V_{OUT} = V_{SS} - V_{GG} = -53\text{ V}$		—	10.0	μA	
Current Consumption	I_{SS}	No load		—	10.0	mA	

AC Characteristics

 $(V_{SS} = 5\text{ V} \pm 10\%, V_{GG} = -53\text{ V} \pm 0.5\text{ V}, T_a = -40\text{ to } +85^\circ\text{C})$

Parameter	Symbol	Condition	Min.	Max.	Unit
Self-oscillation Frequency	f_{OSC}	—	392	548	kHz
Frame Frequency	f_{FR}	—	88	332	Hz
Clock Frequency	f_C	—	—	500	kHz
SCLK "H" Time	t_{CW-H}	—	1.0	—	μs
SCLK "L" Time	t_{CW-L}	—	1.0	—	μs
Data Set-up Time	t_{DS}	—	200	—	ns
Data Hold Time	t_{DH}	—	100	—	ns
V_{SS} Rise Time	t_{PRZ}	When unit mounted	100	—	μs
POR Pulse Width	t_{RESW}	—	200	—	μs
POR-SCLK Time	t_{RESS}	—	200	—	ns
Internal Processing Time	t_{BUSY}	—	40	—	μs

TIMING DIAGRAM

a) SCLK and Data Timing

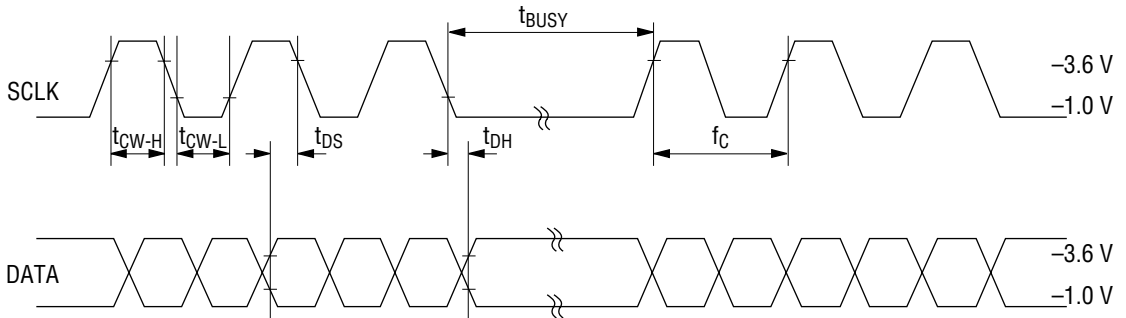

b) V_{SS} Input and Data Word Transfer Timing

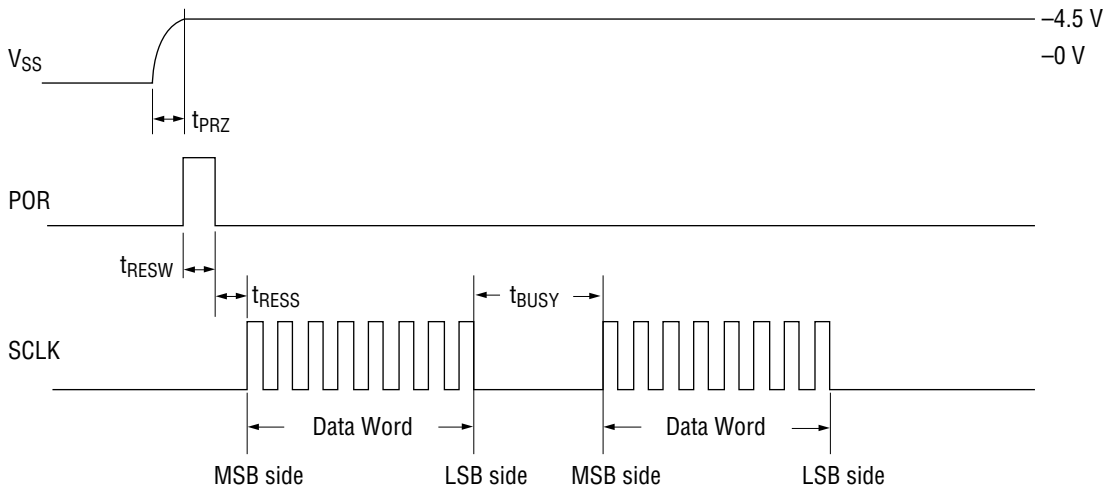

FUNCTIONAL DESCRIPTION

The MSB value of 8-bit serial data determines whether the input data into MSC1951-01 is control data or display data.

Display Data

By setting MSB = "0", the display data can be entered. The address of PLA and set values are specified by bit 5 to bit 0 following MSB.

Tables 1 to 3 provide the PLA code table.

Command	Description	MSB bit7	bit6	bit5	bit4	bit3	bit2	bit1	LSB bit0
Display Data	Set Display contents	0	X	2 ⁵	2 ⁴	2 ³	2 ²	2 ¹	2 ⁰

X: Don't care

Control Data

The control data can be input by setting MSB to "1". In addition, a command type and set values are determined by the bit 6 to bit 0 following MSB.

Command	Function	MSB bit 7	bit 6	bit 5	bit 4	bit 3	bit 2	bit 1	LSB bit 0
Buffer Pointer Control	Specifies the RAM address.	1	0	1	0	2 ³	2 ²	2 ¹	2 ⁰
Digit Counter Control	Sets the number of display digits.	1	1	0	0	2 ³	2 ²	2 ¹	2 ⁰
Duty Cycle Control	Sets the duty value.	1	1	1	2 ⁴	2 ³	2 ²	2 ¹	2 ⁰
Test Mode	Sets the test mode.	1	0	0	2 ⁴	X	X	X	X

X: Don't care

a) Buffer Pointer Control

This command changes the display contents only at an arbitrary digit. (The RAM write address is set.)

To input data into bits 0 to 3, set (desired digit – 2).

(Example) When specifying AD4, the set value is 2 (0010).

Specified Digit	Set Value of Bits 0 to 3	Specified Digit	Set Value of Bits 0 to 3
AD1	15 (1111)	AD9	7 (0111)
AD2	0 (0000)	AD10	8 (1000)
AD3	1 (0001)	AD11	9 (1001)
AD4	2 (0010)	AD12	10 (1010)
AD5	3 (0011)	AD13	11 (1011)
AD6	4 (0100)	AD14	12 (1100)
AD7	5 (0101)	AD15	13 (1101)
AD8	6 (0110)	AD16	14 (1110)

b) Digit Counter Control

This command sets the number of display digits.
Set the desired number of digits in bits 0 to 3.

Number of Display Digits	Set Value of Bits 0 to 3	Number of Display Digits	Set Value of Bits 0 to 3
1	1 (0001)	9	9 (1001)
2	2 (0010)	10	10 (1010)
3	3 (0011)	11	11 (1011)
4	4 (0100)	12	12 (1100)
5	5 (0101)	13	13 (1101)
6	6 (0110)	14	14 (1110)
7	7 (0111)	15	15 (1111)
8	8 (1000)	16	0 (0000)

c) Duty Cycle Control

This command sets the duty cycle of the driver output. This command allows the brightness to be adjusted by 1/32 step. As shown in Figure 1, the blank time between digits or between the segments is specified by 1 bit time on the hardware. Therefore, the set value ranges from 0 to 31.

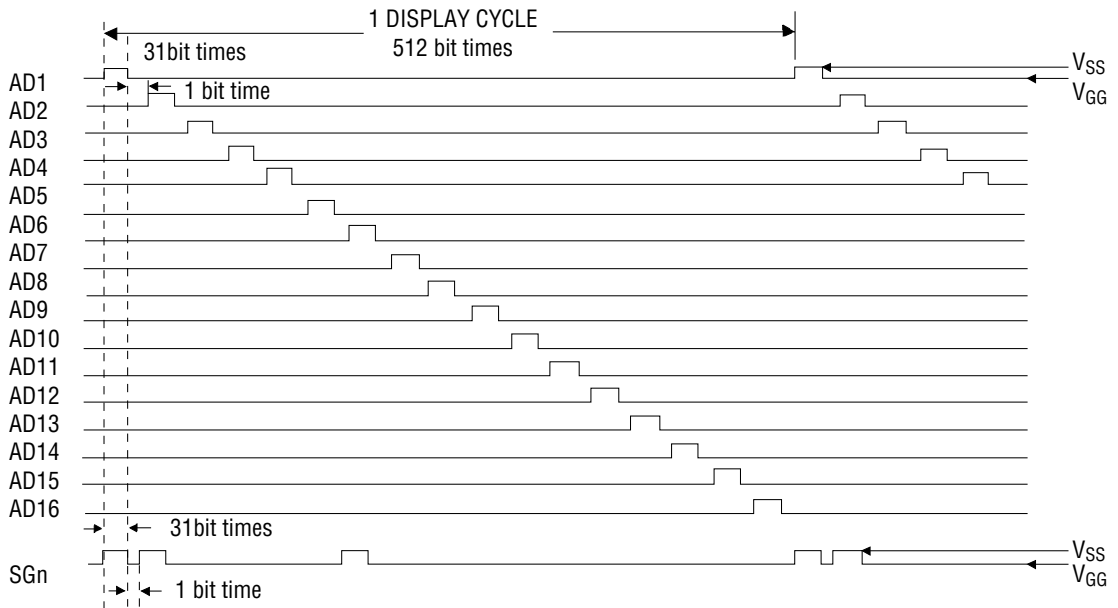

Note: At the time of Duty Cycle = 31 (1 bit time = $5 \times 1/f_{osc}$)

Fig. 1 Output Timing

d) Test Mode

This mode is not a user function, but is used for outgoing inspection.

Table 1 PLA Code Table

Input Code	Function	Segment Driver Output Patterns (1 = On)																	
		SGA	SGB	SGC	SGD	SGE	SGF	SGG	SGH	SGI	SGJ	SGK	SSL	SGM	SGN	SGO	SGP	PNT	TAIL
0 X 0 0 0 0 0 0 0	Segment A On	1																	
0 X 0 0 0 0 0 0 1	Segment B On		1																
0 X 0 0 0 0 0 1 0	Segment C On			1															
0 X 0 0 0 0 0 1 1	Segment D On				1														
0 X 0 0 0 0 1 0 0	Segment E On					1													
0 X 0 0 0 0 1 0 1	Segment F On						1												
0 X 0 0 0 0 1 1 0	Segment G On							1											
0 X 0 0 0 0 1 1 1	Segment H On								1										
0 X 0 0 0 1 0 0 0	Segment I On									1									
0 X 0 0 0 1 0 0 1	Segment J On										1								
0 X 0 0 0 1 0 1 0	Segment K On											1							
0 X 0 0 0 1 0 1 1	Segment L On												1						
0 X 0 0 0 1 1 0 0	Segment M On													1					
0 X 0 0 0 1 1 0 1	Segment N On														1				
0 X 0 0 0 1 1 1 0	Segment O On															1			
0 X 0 0 0 1 1 1 1	Segment P On																1		
0 X 0 1 0 0 0 0 0	Segment A On	1																	
0 X 0 1 0 0 0 0 1	Segment A & B On	1	1																
0 X 0 1 0 0 0 1 0	Segment A-C On	1	1	1															
0 X 0 1 0 0 0 1 1	Segment A-D On	1	1	1	1														
0 X 0 1 0 1 0 0 0	Segment A-E On	1	1	1	1	1													
0 X 0 1 0 1 0 0 1	Segment A-F On	1	1	1	1	1	1												
0 X 0 1 0 1 1 0 0	Segment A-G On	1	1	1	1	1	1	1											
0 X 0 1 0 1 1 0 1	Segment A-H On	1	1	1	1	1	1	1	1										
0 X 0 1 1 0 0 0 0	Segment A-I On	1	1	1	1	1	1	1	1	1									
0 X 0 1 1 0 0 0 1	Segment A-J On	1	1	1	1	1	1	1	1	1	1								
0 X 0 1 1 0 1 0 0	Segment A-K On	1	1	1	1	1	1	1	1	1	1	1							
0 X 0 1 1 0 1 0 1	Segment A-L On	1	1	1	1	1	1	1	1	1	1	1	1						
0 X 0 1 1 1 0 0 0	Segment A-M On	1	1	1	1	1	1	1	1	1	1	1	1	1					
0 X 0 1 1 1 0 0 1	Segment A-N On	1	1	1	1	1	1	1	1	1	1	1	1	1	1				
0 X 0 1 1 1 1 0 0	Segment A-O On	1	1	1	1	1	1	1	1	1	1	1	1	1	1	1			
0 X 0 1 1 1 1 0 1	Segment A-P On	1	1	1	1	1	1	1	1	1	1	1	1	1	1	1	1		
0 X 1 0 0 0 0 0 0	Number 0	1	1	1	1	1	1												
0 X 1 0 0 0 0 0 1	Number 1	1	1	1															
0 X 1 0 0 0 0 1 0	Number 2	1	1	1	1	1		1											
0 X 1 0 0 0 0 1 1	Number 3	1	1	1	1			1	1										
0 X 1 0 0 0 1 0 0	Number 4	1	1	1			1	1	1	1									
0 X 1 0 0 0 1 0 1	Number 5	1	1	1	1		1	1	1	1	1								
0 X 1 0 0 0 1 1 0	Number 6	1	1	1	1	1		1	1	1	1	1							
0 X 1 0 0 0 1 1 1	Number 7	1	1	1	1	1		1	1	1	1	1	1						
0 X 1 0 0 1 0 0 0	Number 8	1	1	1	1	1	1	1	1	1	1	1	1						
0 X 1 0 0 1 0 0 1	Number 9	1	1	1	1	1	1	1	1	1	1	1	1						
0 X 1 0 1 0 0 1 0	Letter P	1	1										1	1	1	1	1		
0 X 1 0 1 0 0 1 1	Letter L	1	1										1	1	1	1	1		
0 X 1 0 1 1 0 0 0	Comma				1	1	1						1	1	1	1	1		
0 X 1 0 1 1 0 0 1	Blank								1	1	1	1	1	1	1	1	1	1	1
0 X 1 0 1 1 1 0 0	Decimal												1	1	1	1	1	1	1
0 X 1 0 1 1 1 0 1	Blank												1	1	1	1	1	1	1
0 X 1 1 0 0 0 0 0	Number 0	1	1	1	1	1	1						1	1	1	1	1	1	1
0 X 1 1 0 0 0 0 1	Number 1	1	1	1									1	1	1	1	1	1	1
0 X 1 1 0 0 0 1 0	Number 2	1	1	1	1	1		1					1	1	1	1	1	1	1
0 X 1 1 0 0 0 1 1	Number 3	1	1	1	1	1		1	1				1	1	1	1	1	1	1
0 X 1 1 0 0 1 0 0	Number 4	1	1	1			1	1					1	1	1	1	1	1	1
0 X 1 1 0 0 1 0 1	Number 5	1	1	1	1	1	1						1	1	1	1	1	1	1
0 X 1 1 0 0 1 1 0	Number 6	1	1	1	1	1	1	1					1	1	1	1	1	1	1
0 X 1 1 0 0 1 1 1	Number 7	1	1	1	1	1	1	1	1				1	1	1	1	1	1	1
0 X 1 1 1 0 0 0 0	Number 8	1	1	1	1	1	1	1	1	1			1	1	1	1	1	1	1
0 X 1 1 1 0 0 0 1	Number 9	1	1	1	1	1	1	1	1	1			1	1	1	1	1	1	1
0 X 1 1 1 0 1 0 0	Letter A	1	1			1	1	1	1	1			1	1	1	1	1	1	1
0 X 1 1 1 0 1 0 1	Letter B	1	1			1	1	1	1	1			1	1	1	1	1	1	1
0 X 1 1 1 1 0 0 0	Letter C	1			1	1	1	1	1	1			1	1	1	1	1	1	1
0 X 1 1 1 1 0 0 1	Letter D	1		1	1	1	1	1	1	1			1	1	1	1	1	1	1
0 X 1 1 1 1 1 0 0	Letter E	1			1	1	1	1	1	1			1	1	1	1	1	1	1
0 X 1 1 1 1 1 0 1	Letter F	1			1	1	1	1	1	1			1	1	1	1	1	1	1

Any 1 of 16 Segments

Bargraph Codes

1 to 16 Segments

Alphanumeric and Special Codes

Table 2 PLA Code (At the time of 7-segment Display)

00	—	08		10	—	18	□	20	□	28	□	30	□	38	□
01		09		11	—	19	□	21	—	29	□	31	—	39	□
02		0A		12	—	1A	□	22	—	2A	□	32	—	3A	□
03	—	0B		13	—□	1B	□	23	—□	2B	—	33	—□	3B	□
04		0C		14	—□	1C	□	24	—	2C	;	34	—	3C	—
05		0D		15	—□	1D	□	25	—	2D		35	—	3D	□
06	—	0E		16	—□	1E	□	26	—	2E	•	36	—	3E	□
07		0F		17	—□	1F	□	27	—	2F		37	—	3F	—

SGP —
 SGO —
 SGN —
 SGM —
 SGL —
 SGK —
 SGJ —
 SGI —
 SGH —
 SGG —
 SGF —
 SGE —
 SGD —
 SGC —
 SGB —
 SGA —

16-SEGMENT
BARGRAPH

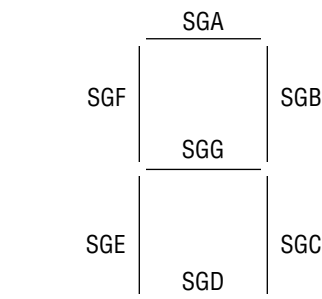

PNT
TAIL

7-SEGMENT
ALPHANUMERIC

* To set the comma and point, the display data at the display digit is input, then 2C and 2E data are input.

Note: Only when 2C and 2E data are entered, the write address in the RAM is not automatically incremented. For other data, the address specified by the Buffer Pointer Control command is automatically incremented by one each time the display data is input.

APPLICATION CIRCUIT

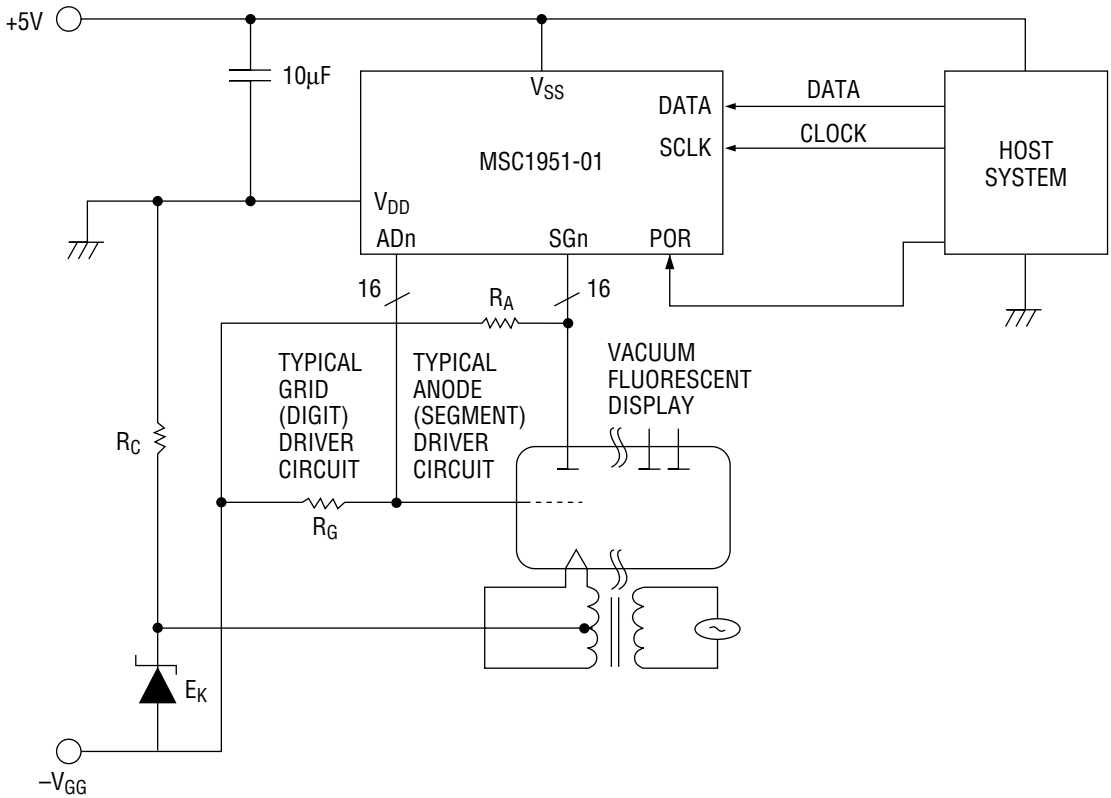

PACKAGE DIMENSIONS

(Unit : mm)

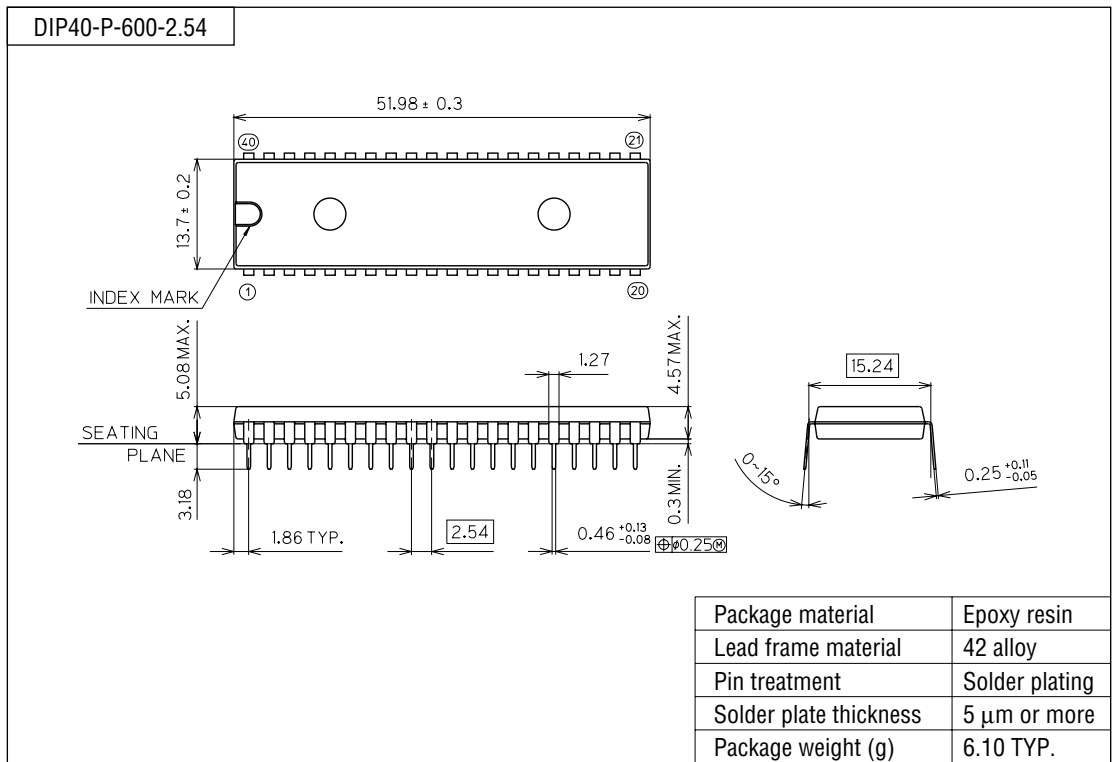

Notes for Mounting the Surface Mount Type Package

The SOP, QFP, TSOP, SOJ, QFJ (PLCC), SHP and BGA are surface mount type packages, which are very susceptible to heat in reflow mounting and humidity absorbed in storage. Therefore, before you perform reflow mounting, contact Oki's responsible sales person for the product name, package name, pin number, package code and desired mounting conditions (reflow method, temperature and times).

(Unit : mm)

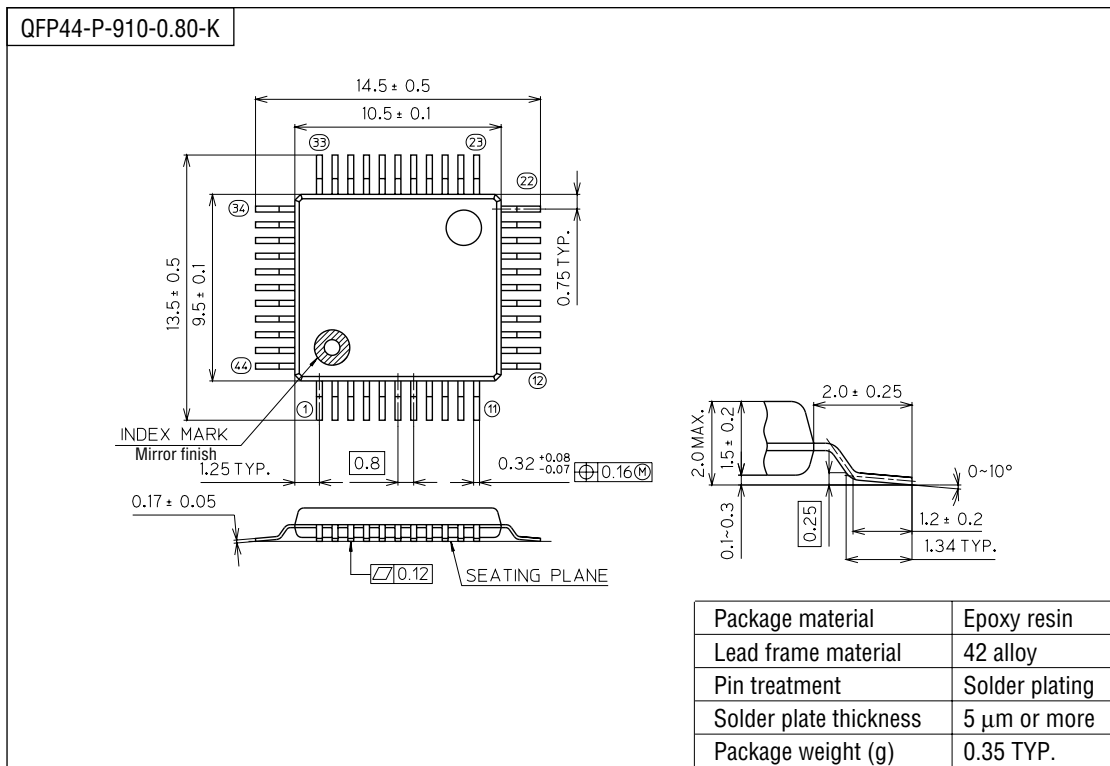

Notes for Mounting the Surface Mount Type Package

The SOP, QFP, TSOP, SOJ, QFJ (PLCC), SHP and BGA are surface mount type packages, which are very susceptible to heat in reflow mounting and humidity absorbed in storage. Therefore, before you perform reflow mounting, contact Oki's responsible sales person for the product name, package name, pin number, package code and desired mounting conditions (reflow method, temperature and times).