

# MSM514400D/DL

**1,048,576-Word × 4-Bit DYNAMIC RAM : FAST PAGE MODE TYPE**

## DESCRIPTION

The MSM514400D/DL is a 1,048,576-word × 4-bit dynamic RAM fabricated in Oki's silicon-gate CMOS technology. The MSM514400D/DL achieves high integration, high-speed operation, and low-power consumption because Oki manufactures the device in a quadruple-layer polysilicon/single-layer metal CMOS process. The MSM514400D/DL is available in a 26/20-pin plastic SOJ, 20-pin plastic ZIP, or 26/20-pin plastic TSOP. The MSM514400DL (the low-power version) is specially designed for lower-power applications.

## FEATURES

- 1,048,576-word × 4-bit configuration
  - Single 5 V power supply, ±10% tolerance
  - Input : TTL compatible, low input capacitance
  - Output : TTL compatible, 3-state
  - Refresh : 1024 cycles/16 ms, 1024 cycles/128 ms (L-version)
  - Fast page mode, read modify write capability
  - $\overline{\text{CAS}}$  before  $\overline{\text{RAS}}$  refresh, hidden refresh,  $\overline{\text{RAS}}$ -only refresh capability
  - Multi-bit test mode capability
  - Package options:
    - 26/20-pin 300 mil plastic SOJ (SOJ26/20-P-300-1.27) (Product : MSM514400D/DL-xxSJ)
    - 20-pin 400 mil plastic ZIP (ZIP20-P-400-1.27) (Product : MSM514400D/DL-xxZS)
    - 26/20-pin 300 mil plastic TSOP (TSOPII26/20-P-300-1.27-K) (Product : MSM514400D/DL-xxTS-K)
- xx indicates speed rank.

## PRODUCT FAMILY

Family	Access Time (Max.)				Cycle Time (Min.)	Power Dissipation	
	t <sub>RAC</sub>	t <sub>AA</sub>	t <sub>CAC</sub>	t <sub>OEA</sub>		Operating (Max.)	Standby (Max.)
MSM514400D/DL-50	50 ns	25 ns	13 ns	13 ns	90 ns	550 mW	5.5 mW/ 1.1 mW (L-version)
MSM514400D/DL-60	60 ns	30 ns	15 ns	15 ns	110 ns	495 mW	
MSM514400D/DL-70	70 ns	35 ns	20 ns	20 ns	130 ns	440 mW	

**PIN CONFIGURATION (TOP VIEW)**

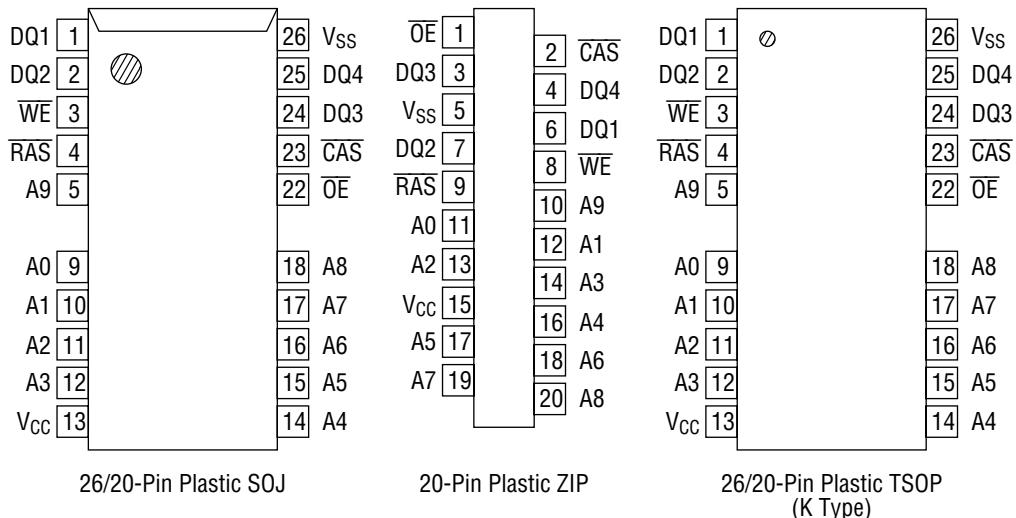

Pin Name	Function
A0 - A9	Address Input
$\overline{\text{RAS}}$	Row Address Strobe
$\overline{\text{CAS}}$	Column Address Strobe
DQ1 - DQ4	Data Input/Data Output
$\overline{\text{OE}}$	Output Enable
$\overline{\text{WE}}$	Write Enable
V <sub>CC</sub>	Power Supply (5 V)
V <sub>SS</sub>	Ground (0 V)

**BLOCK DIAGRAM**

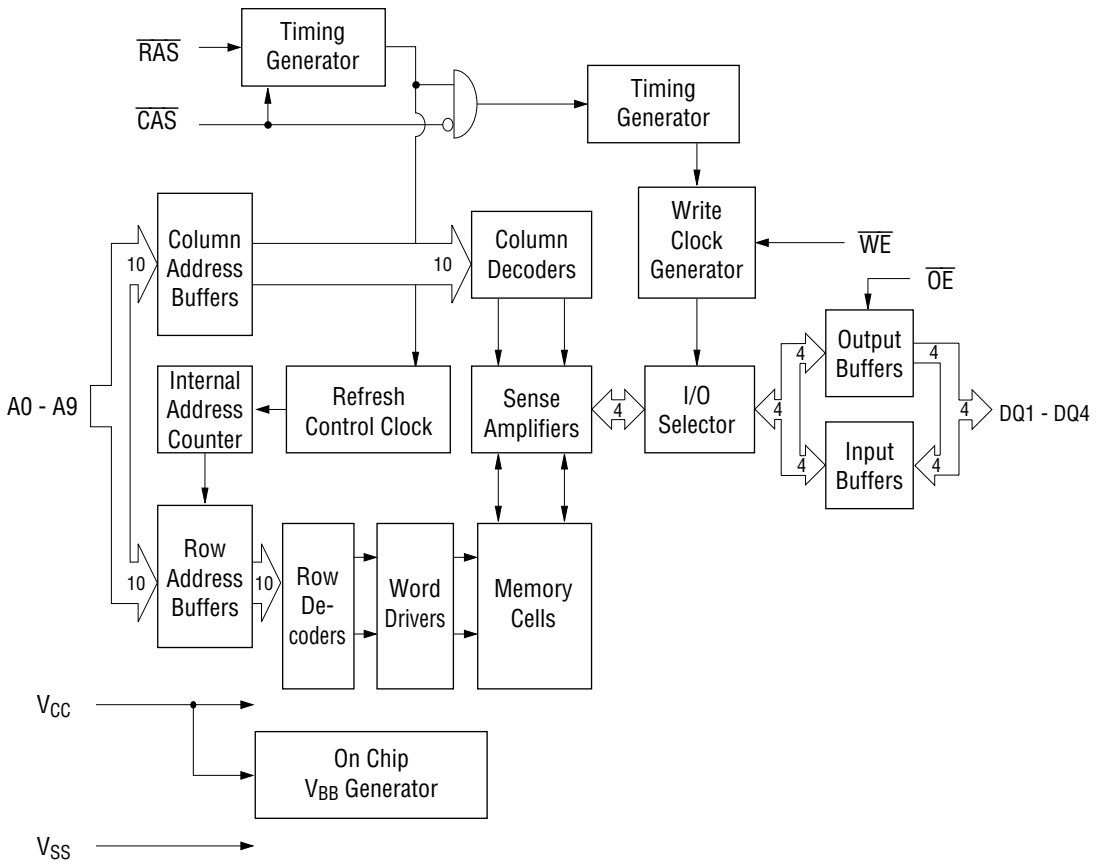

**ELECTRICAL CHARACTERISTICS****Absolute Maximum Ratings**

Parameter	Symbol	Rating	Unit
Voltage on Any Pin Relative to V <sub>SS</sub>	V <sub>T</sub>	-1.0 to 7.0	V
Short Circuit Output Current	I <sub>OS</sub>	50	mA
Power Dissipation	P <sub>D</sub> *	1	W
Operating Temperature	T <sub>opr</sub>	0 to 70	°C
Storage Temperature	T <sub>stg</sub>	-55 to 150	°C

\*: Ta = 25°C

**Recommended Operating Conditions**

(Ta = 0°C to 70°C)

Parameter	Symbol	Min.	Typ.	Max.	Unit
Power Supply Voltage	V <sub>CC</sub>	4.5	5.0	5.5	V
	V <sub>SS</sub>	0	0	0	V
Input High Voltage	V <sub>IH</sub>	2.4	—	6.5	V
Input Low Voltage	V <sub>IL</sub>	-1.0	—	0.8	V

**Capacitance**(V<sub>CC</sub> = 5 V ±10%, Ta = 25°C, f = 1 MHz)

Parameter	Symbol	Typ.	Max.	Unit
Input Capacitance (A0 - A9)	C <sub>IN1</sub>	—	6	pF
Input Capacitance ( $\overline{\text{RAS}}$ , $\overline{\text{CAS}}$ , $\overline{\text{WE}}$ , $\overline{\text{OE}}$ )	C <sub>IN2</sub>	—	7	pF
Output Capacitance (DQ1 - DQ4)	C <sub>I/O</sub>	—	7	pF

## DC Characteristics

(V<sub>CC</sub> = 5 V ±10%, T<sub>a</sub> = 0°C to 70°C)

Parameter	Symbol	Condition	MSM514400 D/DL-50		MSM514400 D/DL-60		MSM514400 D/DL-70		Unit	Note
			Min.	Max.	Min.	Max.	Min.	Max.		
Output High Voltage	V <sub>OH</sub>	I <sub>OH</sub> = -5.0 mA	2.4	V <sub>CC</sub>	2.4	V <sub>CC</sub>	2.4	V <sub>CC</sub>	V	
Output Low Voltage	V <sub>OL</sub>	I <sub>OL</sub> = 4.2 mA	0	0.4	0	0.4	0	0.4	V	
Input Leakage Current	I <sub>LI</sub>	0 V ≤ V <sub>I</sub> ≤ 6.5 V; All other pins not under test = 0 V	-10	10	-10	10	-10	10	μA	
Output Leakage Current	I <sub>LO</sub>	DQ disable 0 V ≤ V <sub>O</sub> ≤ 5.5 V	-10	10	-10	10	-10	10	μA	
Average Power Supply Current (Operating)	I <sub>CC1</sub>	$\overline{\text{RAS}}$ , $\overline{\text{CAS}}$ cycling, t <sub>RC</sub> = Min.	—	100	—	90	—	80	mA	1, 2
Power Supply Current (Standby)	I <sub>CC2</sub>	$\overline{\text{RAS}}$ , $\overline{\text{CAS}} = V_{IH}$	—	2	—	2	—	2	mA	1
		$\overline{\text{RAS}}$ , $\overline{\text{CAS}}$ ≥ V <sub>CC</sub> - 0.2 V	—	200	—	200	—	200		
Average Power Supply Current ( $\overline{\text{RAS}}$ -only Refresh)	I <sub>CC3</sub>	$\overline{\text{RAS}}$ cycling, $\overline{\text{CAS}} = V_{IH}$ , t <sub>RC</sub> = Min.	—	100	—	90	—	80	mA	1, 2
Power Supply Current (Standby)	I <sub>CC5</sub>	$\overline{\text{RAS}} = V_{IH}$ , $\overline{\text{CAS}} = V_{IL}$ , DQ = enable	—	5	—	5	—	5	mA	1
Average Power Supply Current ( $\overline{\text{CAS}}$ before $\overline{\text{RAS}}$ Refresh)	I <sub>CC6</sub>	$\overline{\text{RAS}}$ cycling, $\overline{\text{CAS}}$ before $\overline{\text{RAS}}$	—	100	—	90	—	80	mA	1, 2
Average Power Supply Current (Fast Page Mode)	I <sub>CC7</sub>	$\overline{\text{RAS}} = V_{IL}$ , $\overline{\text{CAS}}$ cycling, t <sub>PC</sub> = Min.	—	80	—	70	—	60	mA	1, 3
Average Power Supply Current (Battery Backup)	I <sub>CC10</sub>	t <sub>RC</sub> = 125 μs, $\overline{\text{CAS}}$ before $\overline{\text{RAS}}$ , t <sub>RAS</sub> ≤ 1 μs	—	300	—	300	—	300	μA	1, 4, 5

- Notes :
1. I<sub>CC</sub> Max. is specified as I<sub>CC</sub> for output open condition.
  2. The address can be changed once or less while  $\overline{\text{RAS}} = V_{IL}$ .
  3. The address can be changed once or less while  $\overline{\text{CAS}} = V_{IH}$ .
  4. V<sub>CC</sub> - 0.2 V ≤ V<sub>IH</sub> ≤ 6.5 V, -1.0 V ≤ V<sub>IL</sub> ≤ 0.2 V.
  5. L-version.

## AC Characteristics (1/2)

(V<sub>CC</sub> = 5 V ±10%, T<sub>a</sub> = 0°C to 70°C) Note 1, 2, 3, 11, 12

Parameter	Symbol	MSM514400 D/DL-50		MSM514400 D/DL-60		MSM514400 D/DL-70		Unit	Note
		Min.	Max.	Min.	Max.	Min.	Max.		
Random Read or Write Cycle Time	t <sub>RC</sub>	90	—	110	—	130	—	ns	
Read Modify Write Cycle Time	t <sub>RWC</sub>	131	—	150	—	180	—	ns	
Fast Page Mode Cycle Time	t <sub>PC</sub>	35	—	40	—	45	—	ns	
Fast Page Mode Read Modify Write Cycle Time	t <sub>PRWC</sub>	76	—	80	—	95	—	ns	
Access Time from $\overline{\text{RAS}}$	t <sub>RAC</sub>	—	50	—	60	—	70	ns	4, 5, 6
Access Time from $\overline{\text{CAS}}$	t <sub>CAC</sub>	—	13	—	15	—	20	ns	4, 5
Access Time from Column Address	t <sub>AA</sub>	—	25	—	30	—	35	ns	4, 6
Access Time from $\overline{\text{CAS}}$ Precharge	t <sub>CPA</sub>	—	30	—	35	—	40	ns	4
Access Time from $\overline{\text{OE}}$	t <sub>OEA</sub>	—	13	—	15	—	20	ns	4
Output Low Impedance Time from $\overline{\text{CAS}}$	t <sub>CLZ</sub>	0	—	0	—	0	—	ns	4
$\overline{\text{CAS}}$ to Data Output Buffer Turn-off Delay Time	t <sub>OFF</sub>	0	13	0	15	0	20	ns	7
$\overline{\text{OE}}$ to Data Output Buffer Turn-off Delay Time	t <sub>OEZ</sub>	0	13	0	15	0	20	ns	7
Transition Time	t <sub>T</sub>	3	50	3	50	3	50	ns	3
Refresh Period	t <sub>REF</sub>	—	16	—	16	—	16	ms	
Refresh Period (L-version)	t <sub>REF</sub>	—	128	—	128	—	128	ms	
$\overline{\text{RAS}}$ Precharge Time	t <sub>RP</sub>	30	—	40	—	50	—	ns	
$\overline{\text{RAS}}$ Pulse Width	t <sub>RAS</sub>	50	10,000	60	10,000	70	10,000	ns	
$\overline{\text{RAS}}$ Pulse Width (Fast Page Mode)	t <sub>RASP</sub>	50	100,000	60	100,000	70	100,000	ns	
$\overline{\text{RAS}}$ Hold Time	t <sub>RSH</sub>	13	—	15	—	20	—	ns	
$\overline{\text{RAS}}$ Hold Time referenced to $\overline{\text{OE}}$	t <sub>ROH</sub>	10	—	15	—	20	—	ns	
$\overline{\text{CAS}}$ Precharge Time (Fast Page Mode)	t <sub>CP</sub>	10	—	10	—	10	—	ns	
$\overline{\text{CAS}}$ Pulse Width	t <sub>CAS</sub>	13	10,000	15	10,000	20	10,000	ns	
$\overline{\text{CAS}}$ Hold Time	t <sub>CSH</sub>	50	—	60	—	70	—	ns	
$\overline{\text{CAS}}$ to $\overline{\text{RAS}}$ Precharge Time	t <sub>CRP</sub>	5	—	5	—	5	—	ns	
$\overline{\text{RAS}}$ Hold Time from $\overline{\text{CAS}}$ Precharge	t <sub>RHCP</sub>	30	—	35	—	40	—	ns	
$\overline{\text{RAS}}$ to $\overline{\text{CAS}}$ Delay Time	t <sub>RCD</sub>	20	37	20	45	20	50	ns	5
$\overline{\text{RAS}}$ to Column Address Delay Time	t <sub>RAD</sub>	15	25	15	30	15	35	ns	6
Row Address Set-up Time	t <sub>ASR</sub>	0	—	0	—	0	—	ns	
Row Address Hold Time	t <sub>RAH</sub>	10	—	10	—	10	—	ns	
Column Address Set-up Time	t <sub>ASC</sub>	0	—	0	—	0	—	ns	
Column Address Hold Time	t <sub>CAH</sub>	10	—	15	—	15	—	ns	
Column Address Hold Time from $\overline{\text{RAS}}$	t <sub>AR</sub>	45	—	50	—	55	—	ns	
Column Address to $\overline{\text{RAS}}$ Lead Time	t <sub>RAL</sub>	25	—	30	—	35	—	ns	

## AC Characteristics (2/2)

(V<sub>CC</sub> = 5 V ±10%, T<sub>a</sub> = 0°C to 70°C) Note 1, 2, 3, 11, 12

Parameter	Symbol	MSM514400 D/DL-50		MSM514400 D/DL-60		MSM514400 D/DL-70		Unit	Note
		Min.	Max.	Min.	Max.	Min.	Max.		
Read Command Set-up Time	t <sub>RCS</sub>	0	—	0	—	0	—	ns	
Read Command Hold Time	t <sub>RCH</sub>	0	—	0	—	0	—	ns	8
Read Command Hold Time referenced to $\overline{\text{RAS}}$	t <sub>RRH</sub>	0	—	0	—	0	—	ns	8
Write Command Set-up Time	t <sub>WCS</sub>	0	—	0	—	0	—	ns	9
Write Command Hold Time	t <sub>WCH</sub>	10	—	10	—	10	—	ns	
Write Command Hold Time from $\overline{\text{RAS}}$	t <sub>WCR</sub>	40	—	45	—	50	—	ns	
Write Command Pulse Width	t <sub>WP</sub>	10	—	10	—	10	—	ns	
$\overline{\text{OE}}$ Command Hold Time	t <sub>OEH</sub>	13	—	15	—	20	—	ns	
Write Command to $\overline{\text{RAS}}$ Lead Time	t <sub>RWL</sub>	13	—	15	—	20	—	ns	
Write Command to $\overline{\text{CAS}}$ Lead Time	t <sub>CWL</sub>	13	—	15	—	20	—	ns	
Data-in Set-up Time	t <sub>DS</sub>	0	—	0	—	0	—	ns	10
Data-in Hold Time	t <sub>DH</sub>	10	—	15	—	15	—	ns	10
Data-in Hold Time from $\overline{\text{RAS}}$	t <sub>DHR</sub>	45	—	50	—	55	—	ns	
$\overline{\text{OE}}$ to Data-in Delay Time	t <sub>OEED</sub>	13	—	15	—	20	—	ns	
$\overline{\text{CAS}}$ to $\overline{\text{WE}}$ Delay Time	t <sub>CWD</sub>	36	—	35	—	45	—	ns	9
Column Address to $\overline{\text{WE}}$ Delay Time	t <sub>AWD</sub>	48	—	50	—	60	—	ns	9
$\overline{\text{RAS}}$ to $\overline{\text{WE}}$ Delay Time	t <sub>RWD</sub>	73	—	80	—	95	—	ns	9
$\overline{\text{CAS}}$ Precharge $\overline{\text{WE}}$ Delay Time	t <sub>CPWD</sub>	53	—	55	—	65	—	ns	9
$\overline{\text{CAS}}$ Active Delay Time from $\overline{\text{RAS}}$ Precharge	t <sub>RPC</sub>	10	—	10	—	10	—	ns	
$\overline{\text{RAS}}$ to $\overline{\text{CAS}}$ Set-up Time ( $\overline{\text{CAS}}$ before $\overline{\text{RAS}}$ )	t <sub>CSR</sub>	5	—	5	—	5	—	ns	
$\overline{\text{RAS}}$ to $\overline{\text{CAS}}$ Hold Time ( $\overline{\text{CAS}}$ before $\overline{\text{RAS}}$ )	t <sub>CHR</sub>	10	—	10	—	10	—	ns	
$\overline{\text{WE}}$ to $\overline{\text{RAS}}$ Precharge Time ( $\overline{\text{CAS}}$ before $\overline{\text{RAS}}$ )	t <sub>WRP</sub>	10	—	10	—	10	—	ns	
$\overline{\text{WE}}$ Hold Time from $\overline{\text{RAS}}$ ( $\overline{\text{CAS}}$ before $\overline{\text{RAS}}$ )	t <sub>WRH</sub>	10	—	10	—	10	—	ns	
$\overline{\text{RAS}}$ to $\overline{\text{WE}}$ Set-up Time (Test Mode)	t <sub>WTS</sub>	10	—	10	—	10	—	ns	
$\overline{\text{RAS}}$ to $\overline{\text{WE}}$ Hold Time (Test Mode)	t <sub>WTH</sub>	10	—	10	—	10	—	ns	

- Notes:
1. A start-up delay of  $200\ \mu\text{s}$  is required after power-up, followed by a minimum of eight initialization cycles ( $\overline{\text{RAS}}$ -only refresh or  $\overline{\text{CAS}}$  before  $\overline{\text{RAS}}$  refresh) before proper device operation is achieved.
  2. The AC characteristics assume  $t_T = 5\ \text{ns}$ .
  3.  $V_{IH}$  (Min.) and  $V_{IL}$  (Max.) are reference levels for measuring input timing signals. Transition times ( $t_T$ ) are measured between  $V_{IH}$  and  $V_{IL}$ .
  4. This parameter is measured with a load circuit equivalent to 2 TTL loads and 100 pF.
  5. Operation within the  $t_{\text{RCD}}$  (Max.) limit ensures that  $t_{\text{RAC}}$  (Max.) can be met.  $t_{\text{RCD}}$  (Max.) is specified as a reference point only. If  $t_{\text{RCD}}$  is greater than the specified  $t_{\text{RCD}}$  (Max.) limit, then the access time is controlled by  $t_{\text{CAC}}$ .
  6. Operation within the  $t_{\text{RAD}}$  (Max.) limit ensures that  $t_{\text{RAC}}$  (Max.) can be met.  $t_{\text{RAD}}$  (Max.) is specified as a reference point only. If  $t_{\text{RAD}}$  is greater than the specified  $t_{\text{RAD}}$  (Max.) limit, then the access time is controlled by  $t_{\text{AA}}$ .
  7.  $t_{\text{OFF}}$  (Max.) and  $t_{\text{OEZ}}$  (Max.) define the time at which the output achieves the open circuit condition and are not referenced to output voltage levels.
  8.  $t_{\text{RCH}}$  or  $t_{\text{RRH}}$  must be satisfied for a read cycle.
  9.  $t_{\text{WCS}}$ ,  $t_{\text{CWD}}$ ,  $t_{\text{RWD}}$ ,  $t_{\text{AWD}}$  and  $t_{\text{CPWD}}$  are not restrictive operating parameters. They are included in the data sheet as electrical characteristics only. If  $t_{\text{WCS}} \geq t_{\text{WCS}}$  (Min.), then the cycle is an early write cycle and the data out will remain open circuit (high impedance) throughout the entire cycle. If  $t_{\text{CWD}} \geq t_{\text{CWD}}$  (Min.),  $t_{\text{RWD}} \geq t_{\text{RWD}}$  (Min.),  $t_{\text{AWD}} \geq t_{\text{AWD}}$  (Min.) and  $t_{\text{CPWD}} \geq t_{\text{CPWD}}$  (Min.), then the cycle is a read modify write cycle and data out will contain data read from the selected cell; if neither of the above sets of conditions is satisfied, then the condition of the data out (at access time) is indeterminate.
  10. These parameters are referenced to the  $\overline{\text{CAS}}$  leading edge in an early write cycle, and to the  $\overline{\text{WE}}$  leading edge in an  $\overline{\text{OE}}$  control write cycle, or a read modify write cycle.
  11. The test mode is initiated by performing a  $\overline{\text{WE}}$  and  $\overline{\text{CAS}}$  before  $\overline{\text{RAS}}$  refresh cycle. This mode is latched and remains in effect until the exit cycle is generated. The test mode specified in this data sheet is a 2-bit parallel test function. CA0 is not used. In a read cycle, if all internal bits are equal, the DQ pin will indicate a high level. If any internal bits are not equal, the DQ pin will indicate a low level. The test mode is cleared and the memory device returned to its normal operating state by performing a RAS-only refresh cycle or a  $\overline{\text{CAS}}$  before  $\overline{\text{RAS}}$  refresh cycle.
  12. In a test mode read cycle, the value of access time parameters is delayed for 5 ns for the specified value. These parameters should be specified in test mode cycle by adding the above value to the specified value in this data sheet.



### TIMING WAVEFORM

#### Read Cycle

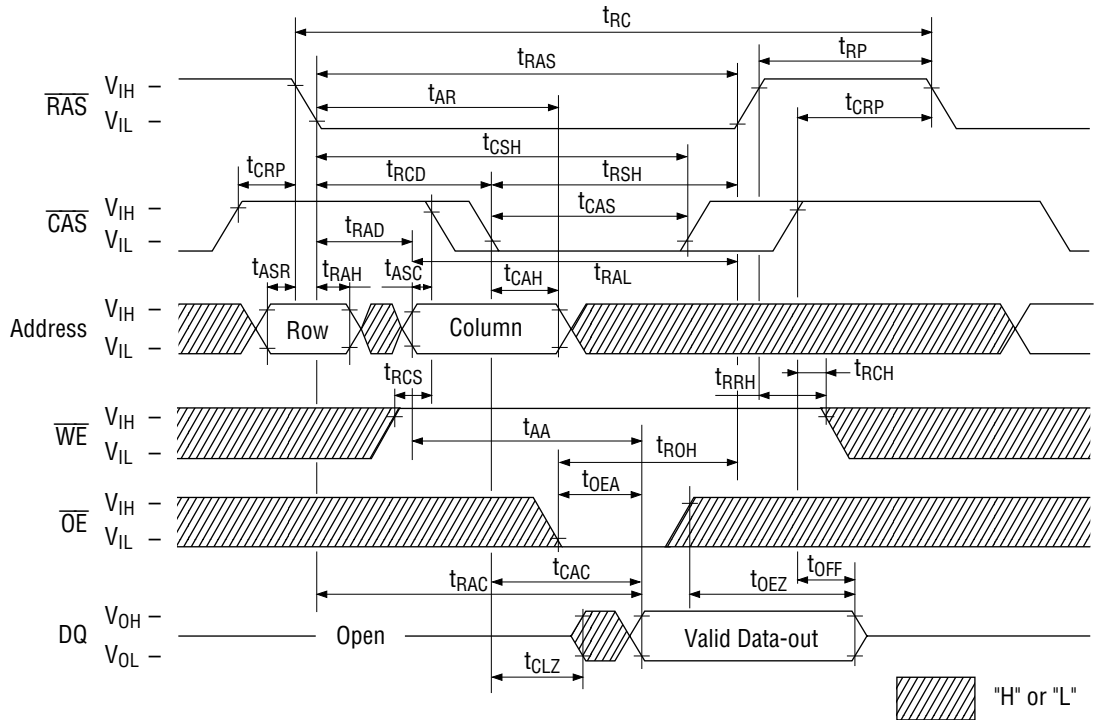

#### Write Cycle (Early Write)

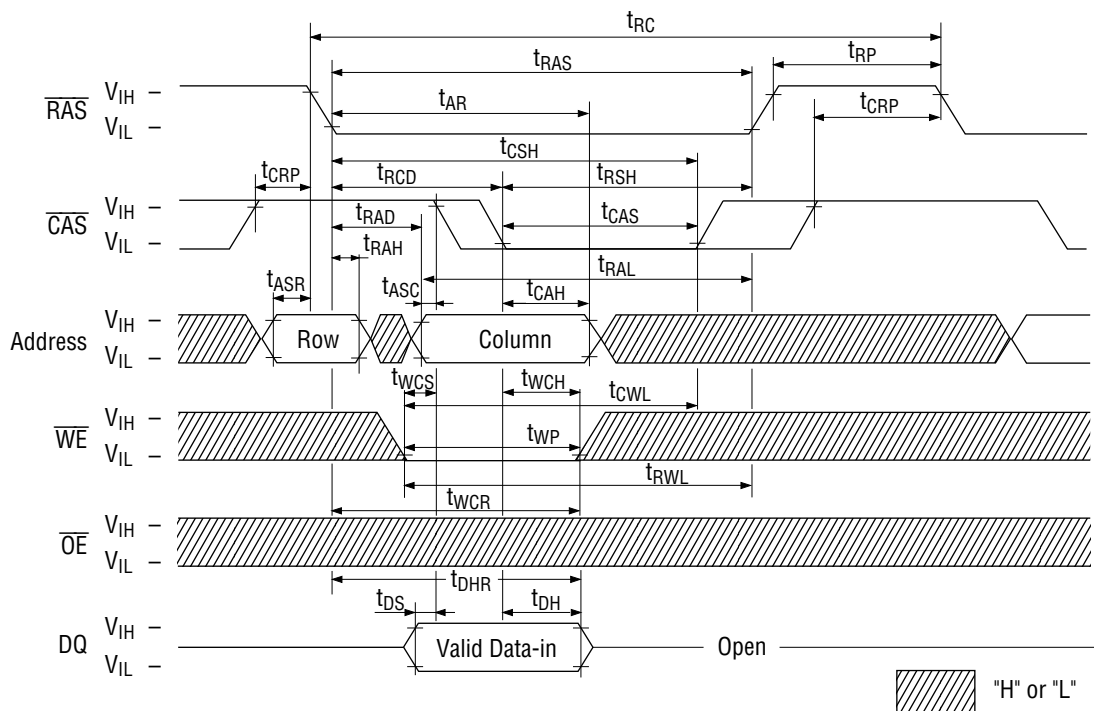

Read Modify Write Cycle

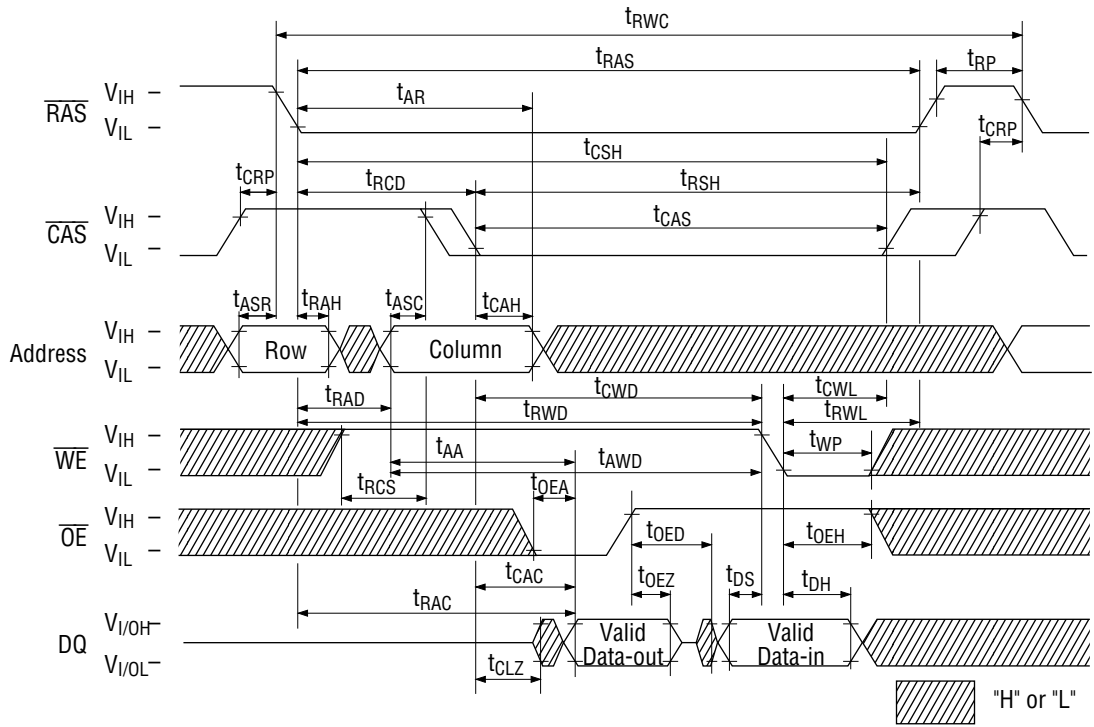



**Fast Page Mode Read Modify Write Cycle**

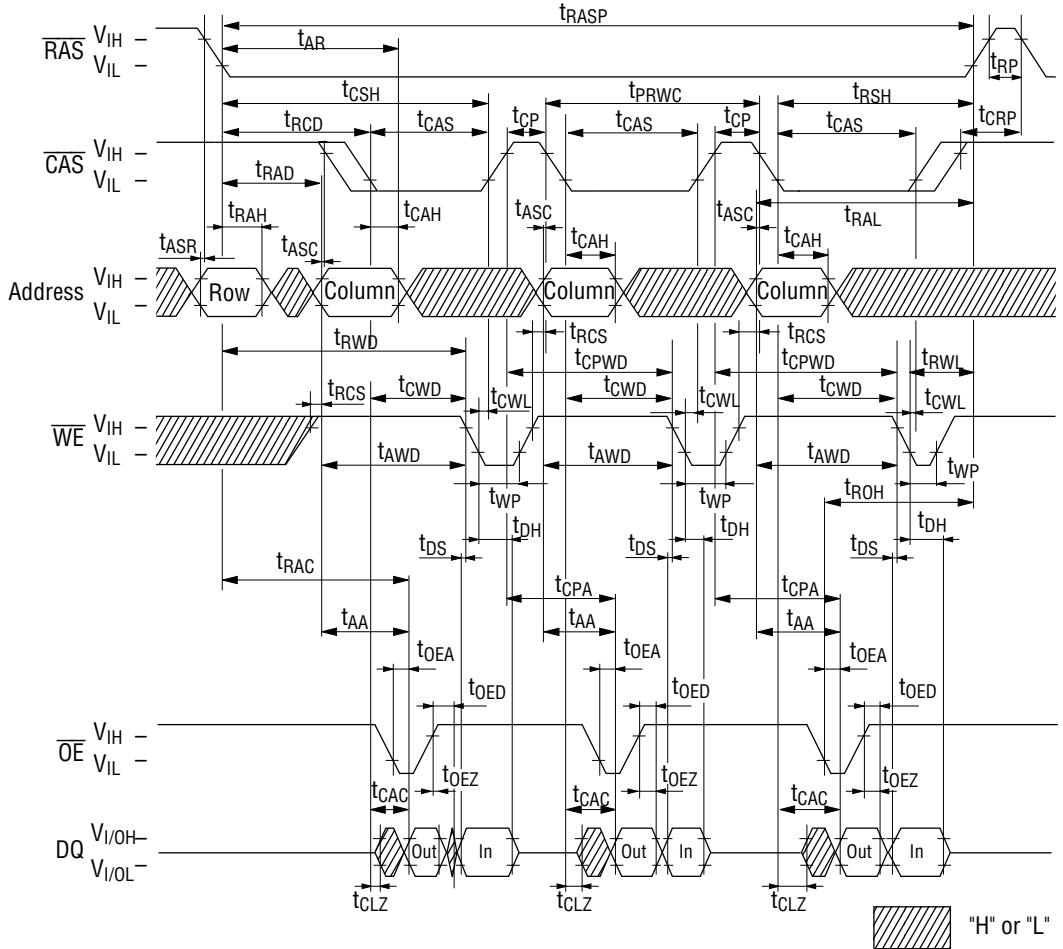

**RAS-Only Refresh Cycle**

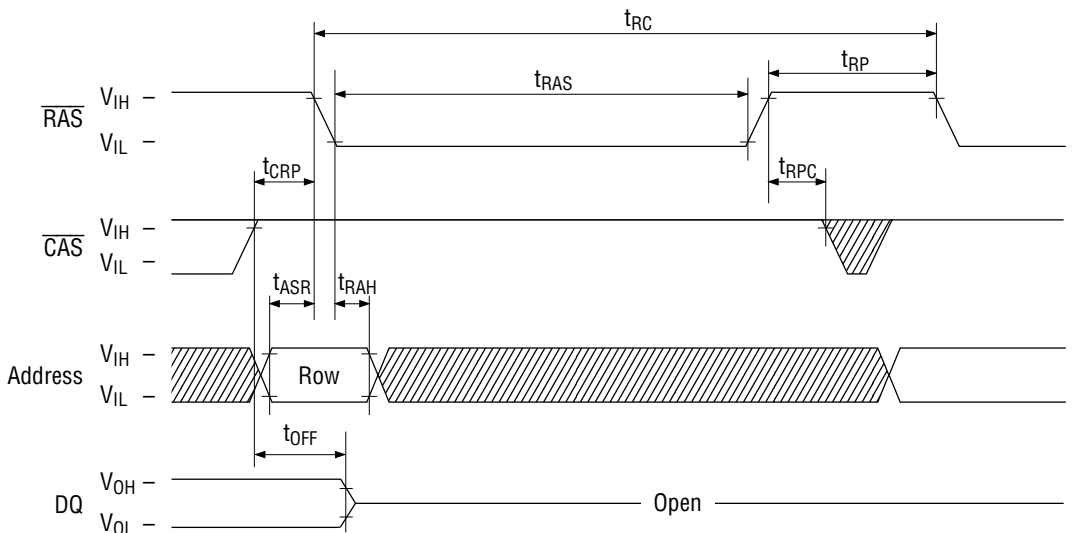

Note:  $\overline{WE}$ ,  $\overline{OE}$  = "H" or "L"

Hatched box = "H" or "L"

### CAS before RAS Refresh Cycle

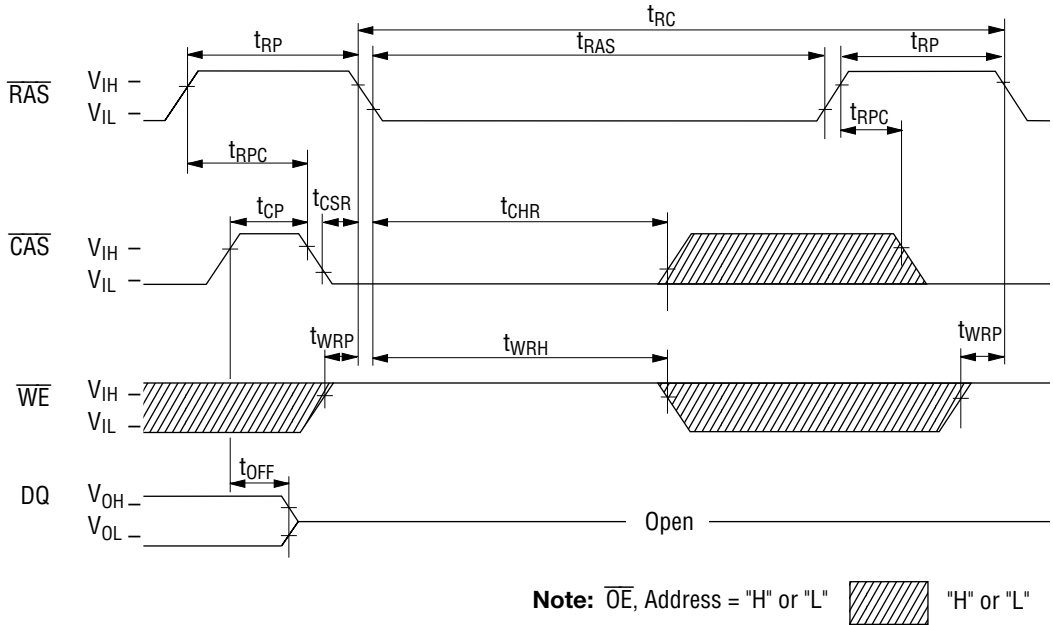

### Hidden Refresh Read Cycle

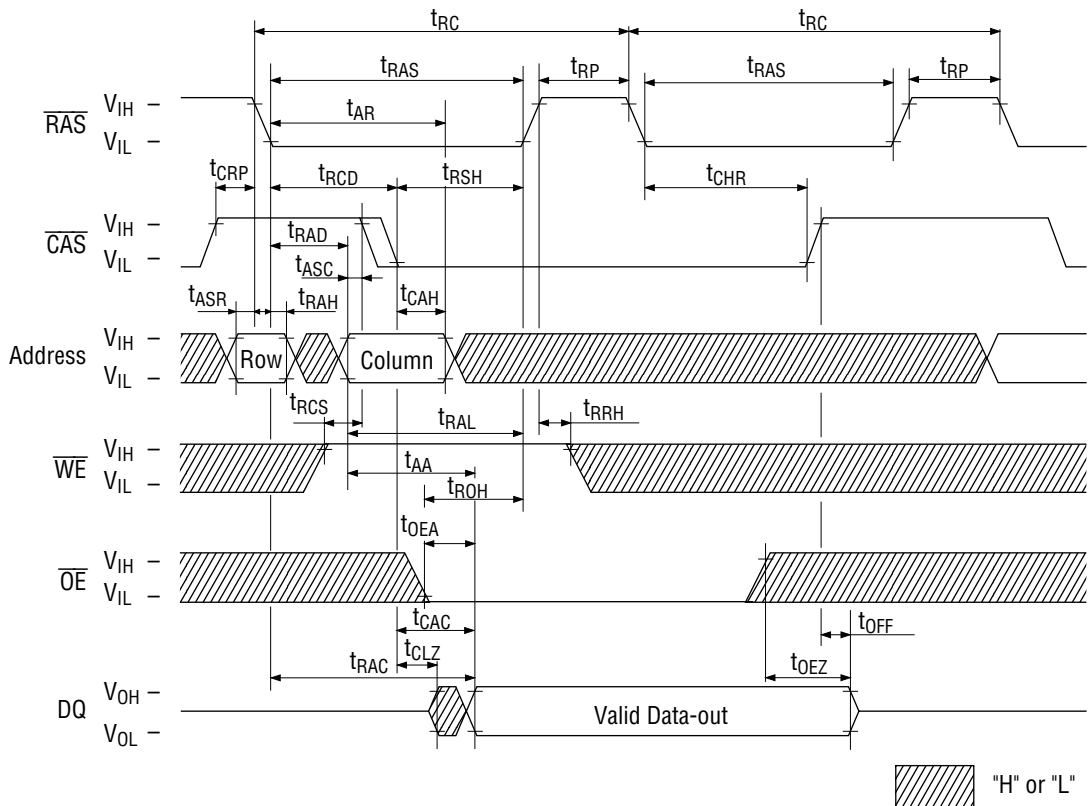

### Hidden Refresh Write Cycle

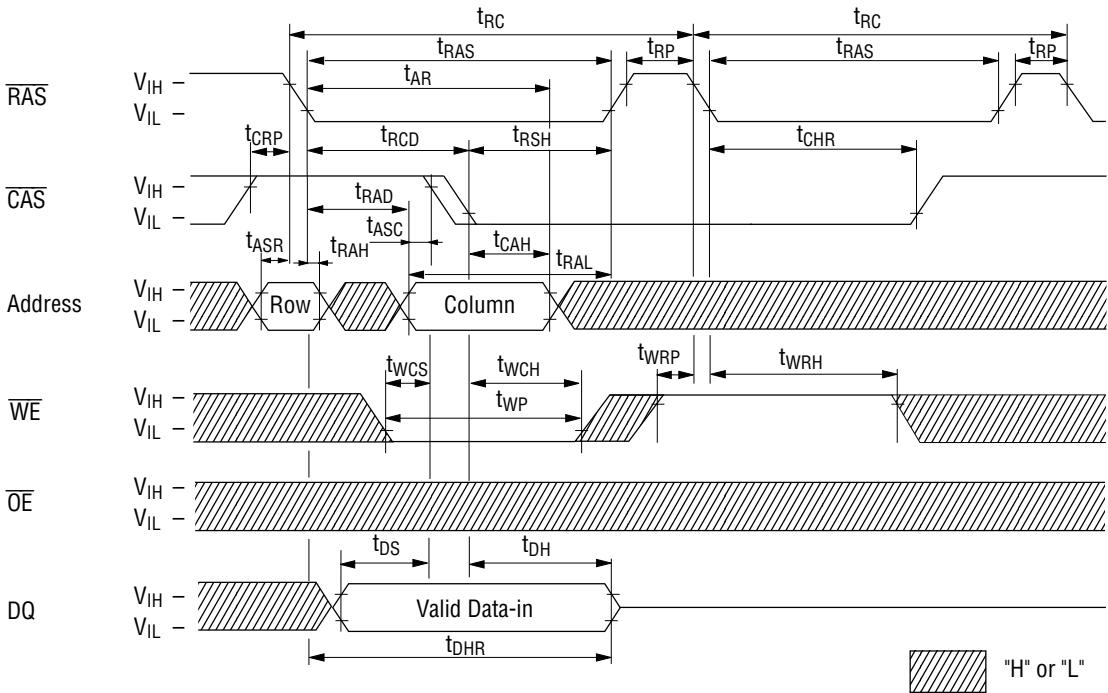

### Test Mode Initiate Cycle

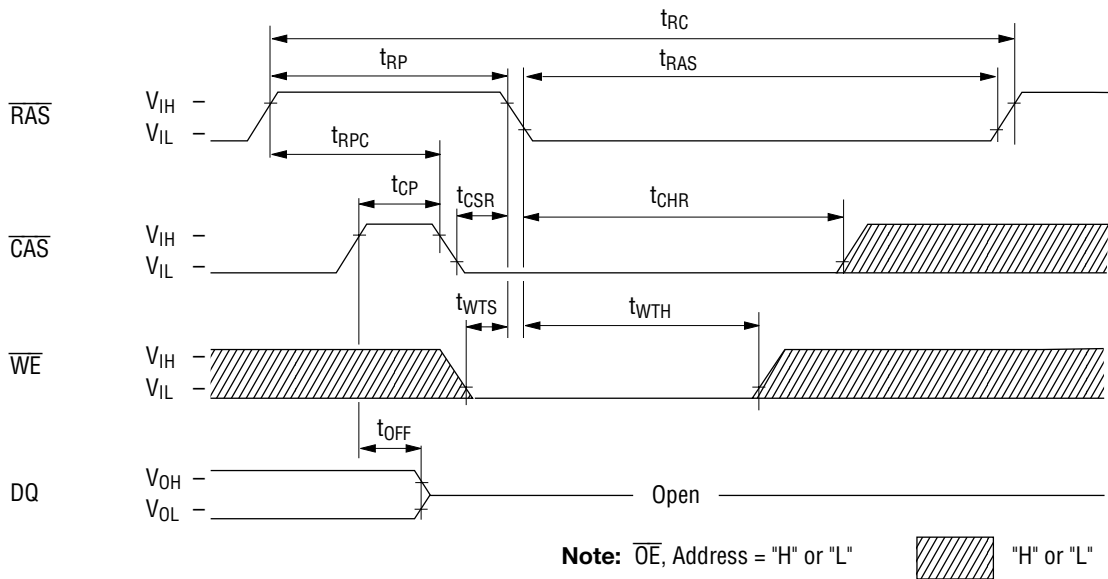

**PACKAGE DIMENSIONS**

(Unit : mm)

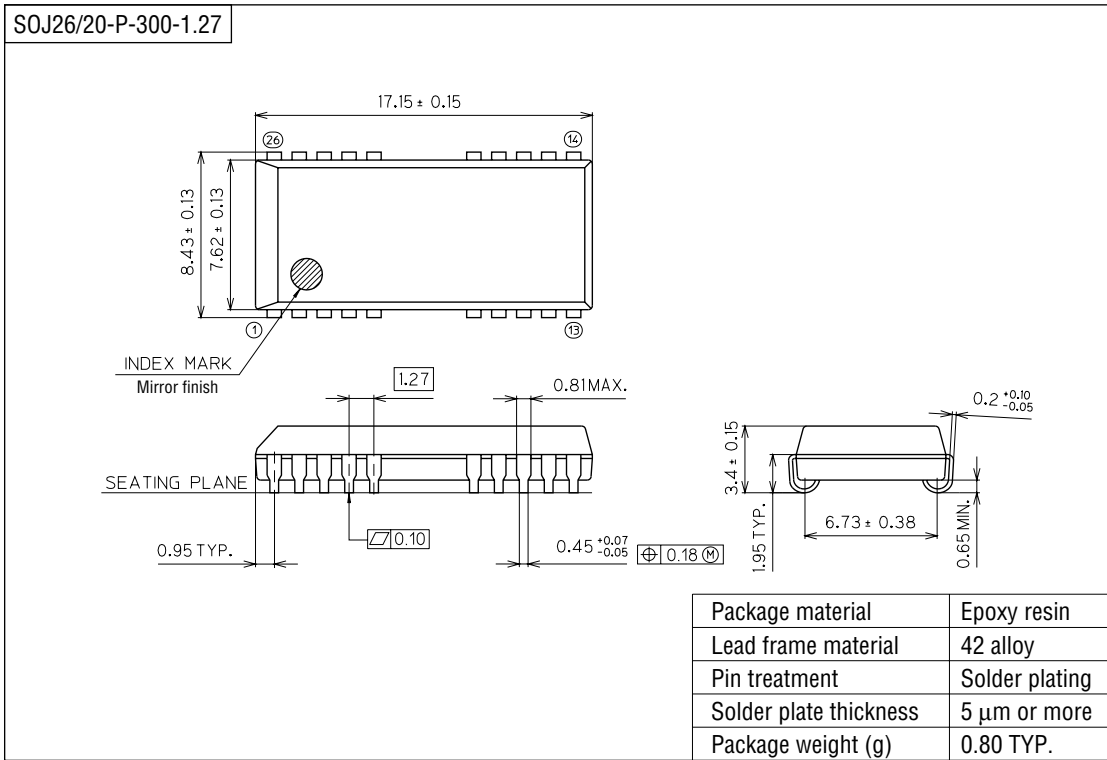

Notes for Mounting the Surface Mount Type Package

The SOP, QFP, TSOP, SOJ, QFJ (PLCC), SHP and BGA are surface mount type packages, which are very susceptible to heat in reflow mounting and humidity absorbed in storage. Therefore, before you perform reflow mounting, contact Oki's responsible sales person for the product name, package name, pin number, package code and desired mounting conditions (reflow method, temperature and times).

(Unit : mm)

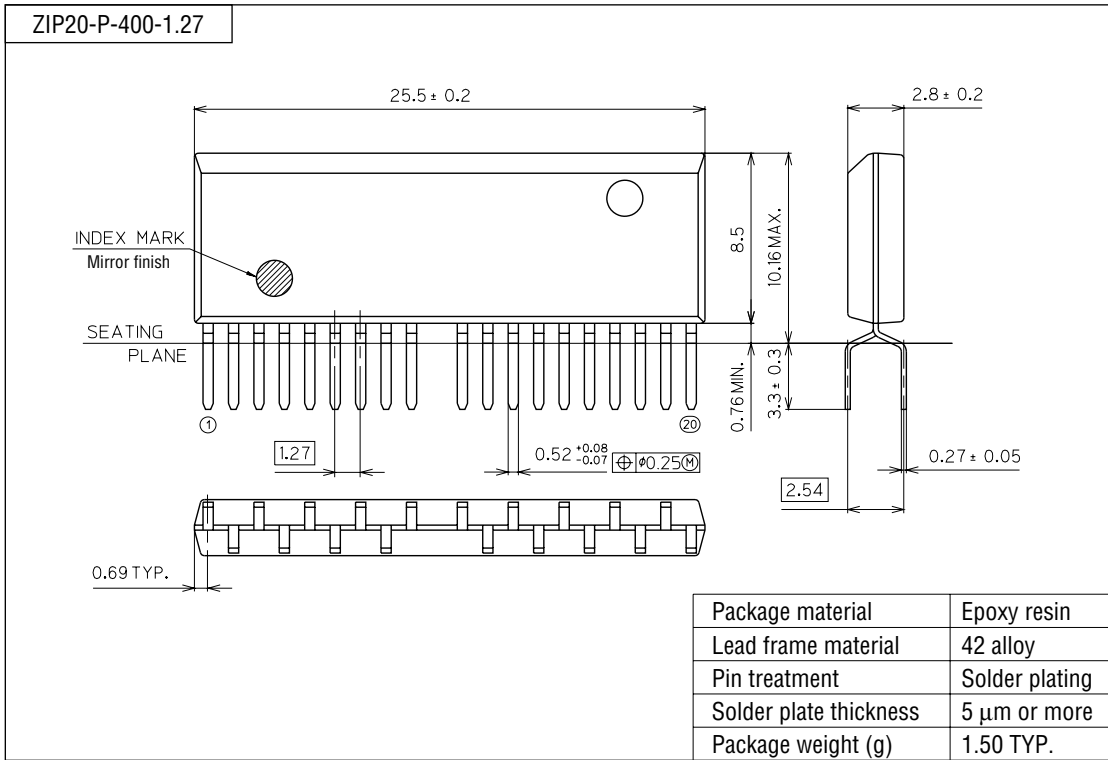



(Unit : mm)

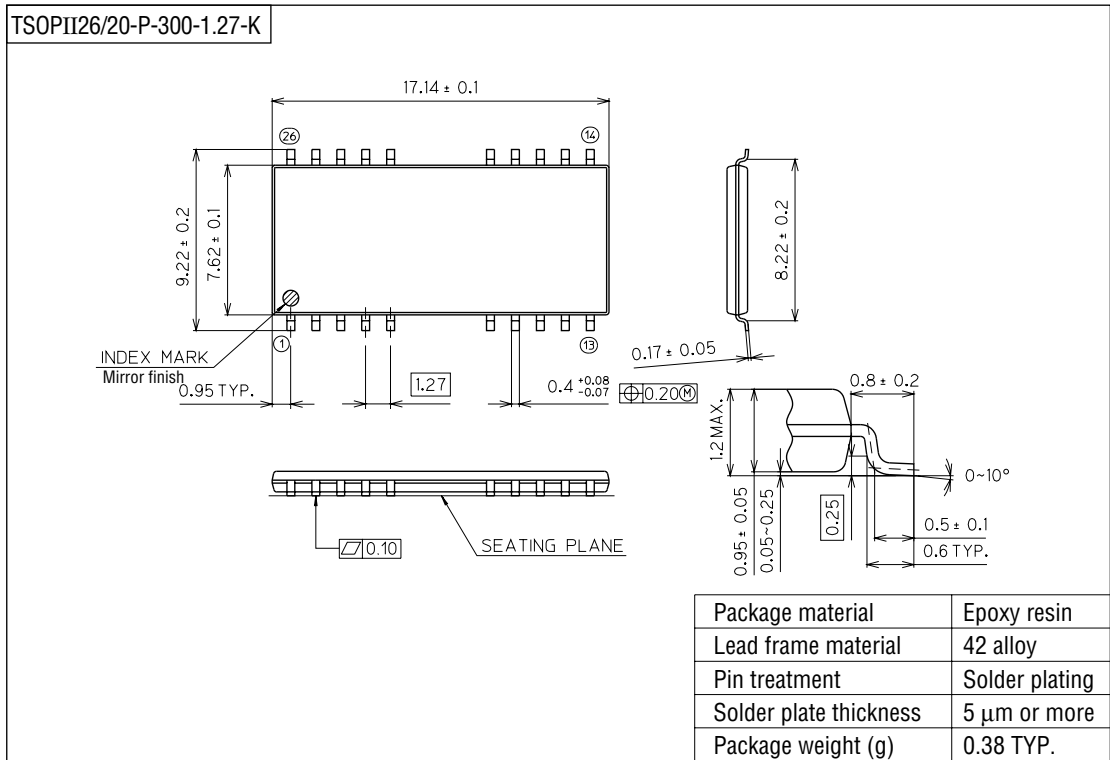

Notes for Mounting the Surface Mount Type Package

The SOP, QFP, TSOP, SOJ, QFJ (PLCC), SHP and BGA are surface mount type packages, which are very susceptible to heat in reflow mounting and humidity absorbed in storage. Therefore, before you perform reflow mounting, contact Oki's responsible sales person for the product name, package name, pin number, package code and desired mounting conditions (reflow method, temperature and times).