MSM6779

160-DOT SEGMENT DRIVER (TCP)

GENERAL DESCRIPTION

The MSM6779 is a LCD dot matrix segment driver. Fabricated in CMOS technology, the device consists of 160-bit latches I and II, a 160-bit level shifter, and a 4-level driver. The MSM6779 latches the 4-bit parallel display data sent from a microcontroller or a LCD controller to generate a LCD driving signal. This MSM6779 has a power-save function that sets all the drivers except one to the low supply current status (I_{DD} SBY).

This driver's 3V-operation allows significant reduction in current consumption, suitable for battery-driving. The bias voltage to specify a drive level can be supplied externally. The MSM6779 can be used for various types of LCD panels.

FEATURES

- Logic supply voltage : 2.7 V to 5.5 V
- LCD drive voltage : A wide range from 14 V to 28 V
- Applicable LCD duty : 1/64 to 1/256
- The bias voltage can be supplied externally.
- LCD outputs : 160
- A power-save function to reduce power consumption in a large-screen LCD panel.
- A 4-bit parallel data transfer to reduces its transfer speed to 1/4 of conventional serial transfer, providing low power consumption.
- Data transfer clock frequency : 6.5 MHz ($V_{DD}=4.5$ V)
4.0 MHz ($V_{DD}=2.7$ V)
- 35mm-wide-film TCP
 - Tin-plating
 - User area : 8 mm

BLOCK DIAGRAM

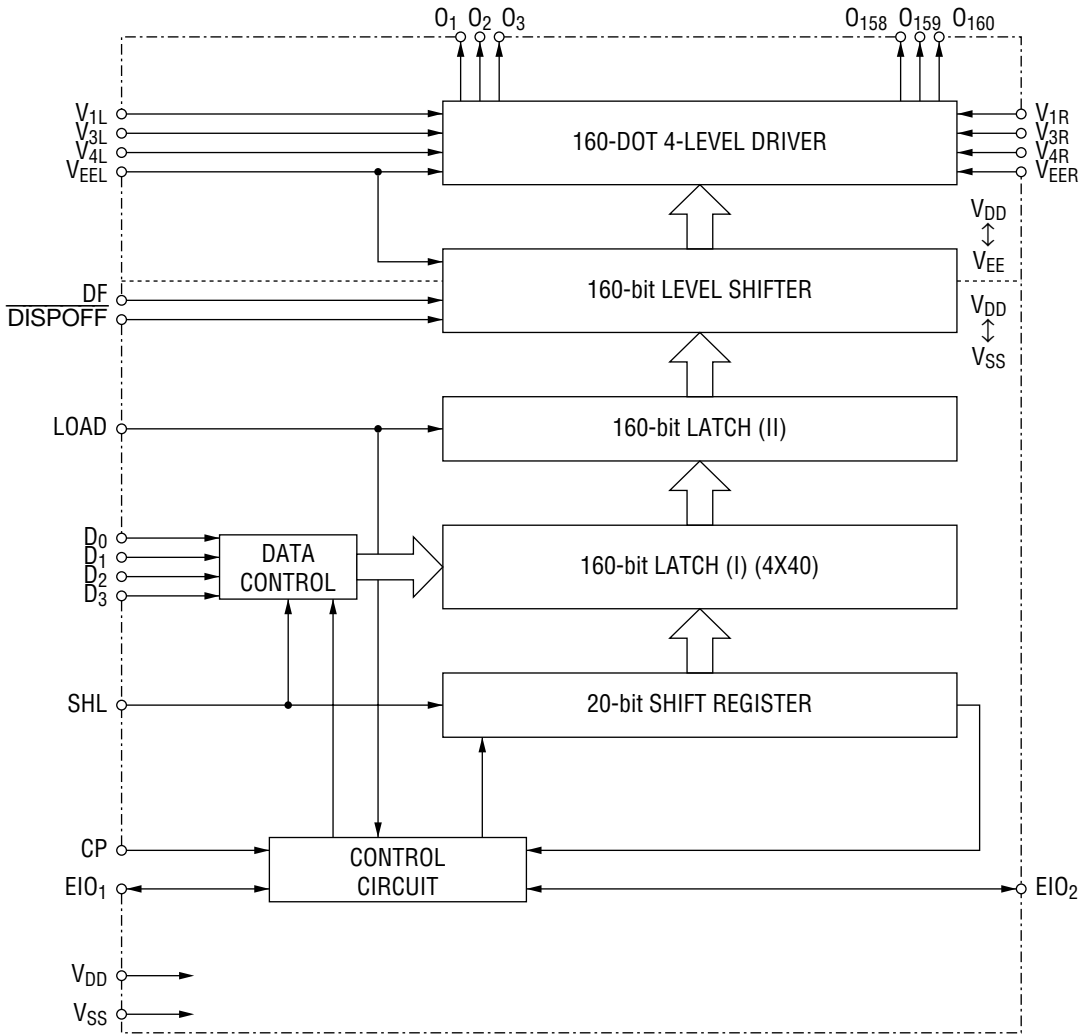

PIN CONFIGURATION (TOP VIEW)

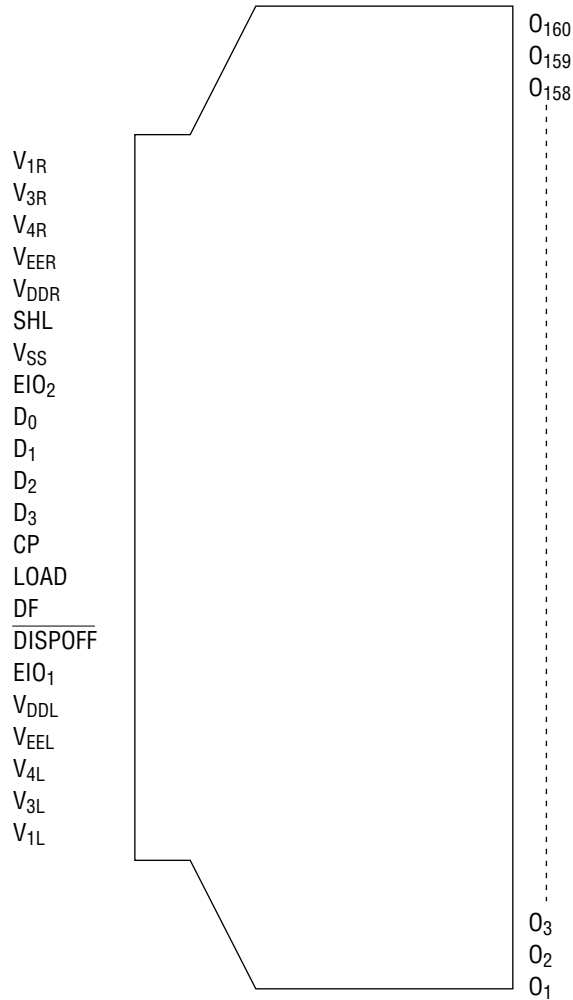

Note: The drawing shown does not specify the exact outline of the TCP; it only specifies the pin layout.

ABSOLUTE MAXIMUM RATINGS

Parameter	Symbol	Condition	Rating	Unit
Supply Voltage (1)	V_{DD}	$T_a=25^{\circ}\text{C}$	-0.3 to 6.5	V
Supply Voltage (2)	$V_{DD}-V_{EE}^{*1}$	$T_a=25^{\circ}\text{C}$	0 to 30	V
Input Voltage	V_I	$T_a=25^{\circ}\text{C}$	-0.3 to $V_{DD}+0.3$	V
Storage Temperature	T_{STG}	—	-30 to +85	$^{\circ}\text{C}$

*1 $V_1 > V_3 > V_4 > V_{EE}$, $V_{DD} \geq V_1 > V_3 \geq V_{DD} - 10\text{ V}$, $V_{EE} + 10\text{ V} \geq V_4 > V_{EE}$
 $V_1 = V_{1L} = V_{1R}$, $V_3 = V_{3L} = V_{3R}$, $V_4 = V_{4L} = V_{4R}$, $V_{EE} = V_{EEL} = V_{EER}$

RECOMMENDED OPERATING CONDITIONS

Parameter	Symbol	Condition	Range	Unit
Supply Voltage (1)	V_{DD}	—	2.7 to 5.5	V
Supply Voltage (2)	$V_{DD}-V_{EE}^{*1}$	—	14 to 28	V
Operating Temperature	Top	—	-20 to +75	$^{\circ}\text{C}$

*1 $V_1 > V_3 > V_4 > V_{EE}$, $V_{DD} \geq V_1 > V_3 \geq V_{DD} - 7\text{ V}$, $V_{EE} + 7\text{ V} \geq V_4 > V_{EE}$
 $V_1 = V_{1L} = V_{1R}$, $V_3 = V_{3L} = V_{3R}$, $V_4 = V_{4L} = V_{4R}$, $V_{EE} = V_{EEL} = V_{EER}$

Note: Unlike mold packages, TCP has a low light resistance. Therefore, they are protected from light.

ELECTRICAL CHARACTERISTICS

DC Characteristics

(V_{DD}=2.7 V to 5.5 V, T_a=-20 to +75°C)

Parameter	Symbol	Condition	Min.	Typ.	Max.	Unit
"H" level Input Voltage	V _{IH}	—*1	0.8 V _{DD}	—	—	V
"L" level Input Voltage	V _{IL}	—*1	—	—	0.2 V _{DD}	V
"H" level Input Current	I _{IH}	V _I =V _{DD} , V _{DD} =5.5 V *1	—	—	1	μA
"L" level Input Current	I _{IL}	V _I =0 V, V _{DD} =5.5 V *1	—	—	-1	μA
"H" level output Voltage	V _{OH}	I _O =-0.2 mA, V _{DD} =2.7 V *2	V _{DD} -0.4	—	—	V
"L" level output Voltage	V _{OL}	I _O =0.2 mA, V _{DD} =2.7 V *2	—	—	0.4	V
ON Resistance	R _{ON}	V _{DD} -V _{EE} =25 V, V _{DD} =2.7 V, I _{VN} -V _O I=0.25 V *3 *4	—	1.5	3.0	kΩ
Stand-by Current Consumption	I _{DD} SBY	f _{CP} =4.0 MHz, V _{DD} =3.0 V V _{DD} -V _{EE} =25 V, No load *5	—	—	300	μA
Current Consumption (1)	I _{DD}	f _{CP} =4.0 MHz, V _{DD} =3.0 V V _{DD} -V _{EE} =25 V, No load *6	—	—	1.5	mA
Current Consumption (2)	I _{EE}	f _{CP} =4.0 MHz, V _{DD} =3.0 V V _{DD} -V _{EE} =25 V, No load *7	—	—	2.0	mA
Current Consumption (3)	I _V	f _{CP} =4.0 MHz, V _{DD} =3.0 V V _{DD} -V _{EE} =25 V, No load *8	—	—	±200	μA
Input Capacitance	C _I	f=1 MHz	—	5	—	pF

*1 Applicable to LOAD, CP, D₀~D₃, EIO₁, EIO₂, SHL, DF, $\overline{\text{DISPOFF}}$ pins*2 Applicable to EIO₁, EIO₂ pins*3 V_N=V_{DD}-V_{EE}, V₄=14/16 (V_{DD}-V_{EE}), V₃=2/16 (V_{DD}-V_{EE}), V_{DD}=V₁*4 Applicable to O₁~O₁₆₀ pins*5 Display data 1010.....f_{DF} = 45 Hz, Current from V_{DD} to V_{SS} when the display data is not fetching.*6 Display data 1010.....f_{DF} = 45 Hz, Current from V_{DD} to V_{SS} when the display data is fetching.*7 Display data 1010.....f_{DF} = 45 Hz, Current from V_{DD} to V_{EE}*8 Display data 1010.....f_{DF} = 45 Hz, Current on V₁, V₃, and V₄ pins.

$$V_1=V_{IL}=V_{IR}, V_3=V_{3L}=V_{3R}, V_4=V_{4L}=V_{4R}, V_{EE}=V_{EEL}=V_{EER}$$

Note: The above values are guaranteed when TCP is protected from light.

Switching Characteristics

($2.7 \leq V_{DD} < 4.5\text{ V}$, $T_a = -20$ to $+75^\circ\text{C}$)

Parameter	Symbol	Condition	Min.	Typ.	Max.	Unit
Clock Frequency	f_{CP}	DUTY=50%, $V_{DD}=2.7\text{ V}$	—	—	4.0	MHz
Clock Pulse Width	t_{W1}	—	90	—	—	ns
Load Pulse Width	t_{W2}	—	110	—	—	ns
Clock Pulse Rise/Fall Time	t_r, t_f	—	—	—	20	ns
Data Set-up Time	t_{DSU}	—	80	—	—	ns
Data Hold Time	t_{DHD}	—	65	—	—	ns
Clock Load Time 1	t_{CL1}	—	0	—	—	ns
Clock Load Time 2	t_{CL2}	—	100	—	—	ns
Load Clock Time 1	t_{LC1}	—	100	—	—	ns
Load Clock Time 2	t_{LC2}	—	100	—	—	ns
Propagation Delay Time	t_{PHL}	$C_L=15\text{ pF}$	—	—	380	ns
EIO ₁ , EIO ₂ Set-up Time	t_{ESU}	—	80	—	—	ns
EIO ₁ , EIO ₂ Hold Time	t_{EHD}	—	80	—	—	ns

Note: The above values are guaranteed when TCP is protected from light.

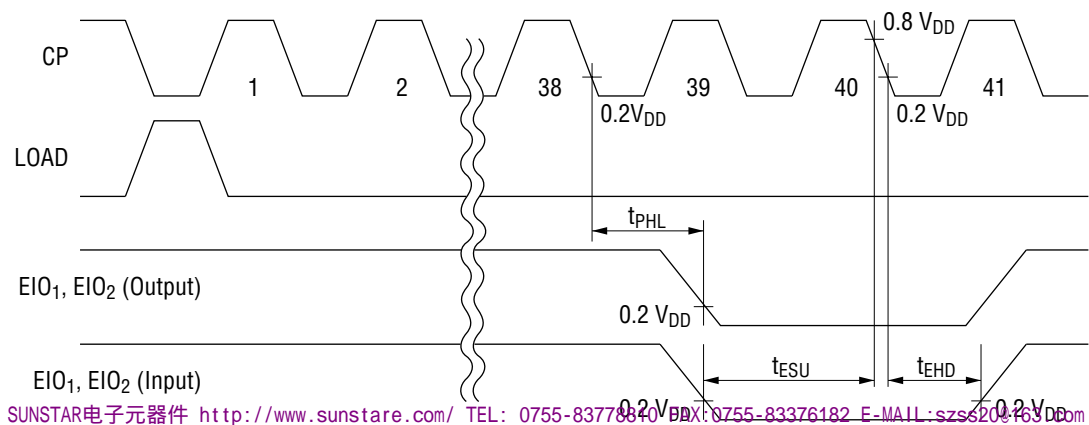
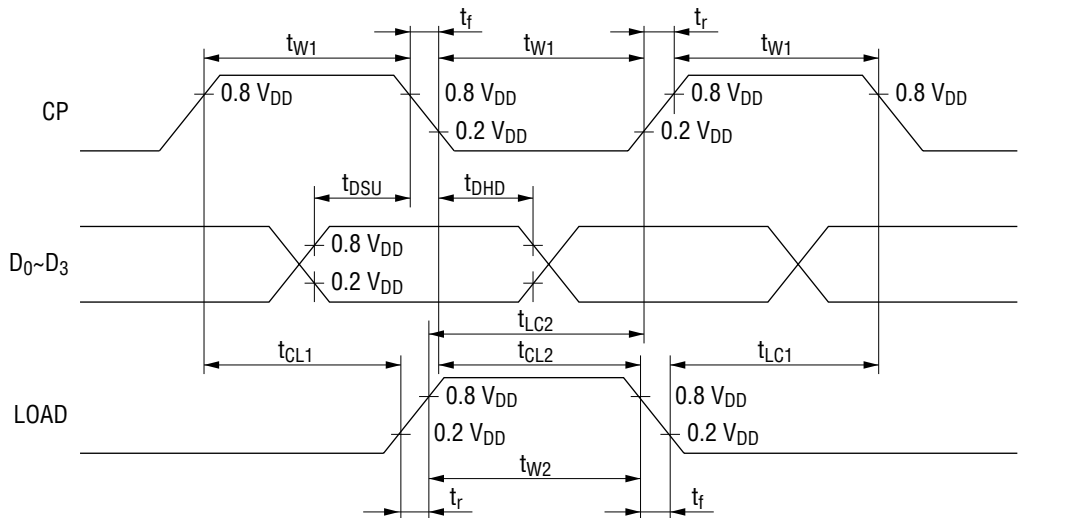

Switching Characteristics

($4.5 \leq V_{DD} \leq 5.5 V$, $T_a = -20$ to $+75^\circ C$)

Parameter	Symbol	Condition	Min.	Typ.	Max.	Unit
Clock Frequency	f_{CP}	DUTY=50%, $V_{DD}=4.5 V$	—	—	6.5	MHz
Clock Pulse Width	t_{W1}	—	56	—	—	ns
Load Pulse Width	t_{W2}	—	70	—	—	ns
Clock Pulse Rise/Fall Time	t_r, t_f	—	—	—	20	ns
Data Set-up Time	t_{DSU}	—	50	—	—	ns
Data Hold Time	t_{DHD}	—	40	—	—	ns
Clock Load Time 1	t_{CL1}	—	0	—	—	ns
Clock Load Time 2	t_{CL2}	—	65	—	—	ns
Load Clock Time 1	t_{LC1}	—	65	—	—	ns
Load Clock Time 2	t_{LC2}	—	65	—	—	ns
Propagation Delay Time	t_{PHL}	$C_L=15 pF$	—	—	236	ns
EIO ₁ , EIO ₂ Set-up Time	t_{ESU}	—	50	—	—	ns
EIO ₁ , EIO ₂ Hold Time	t_{EHD}	—	50	—	—	ns

Note: The above values are guaranteed when TCP is protected from light.

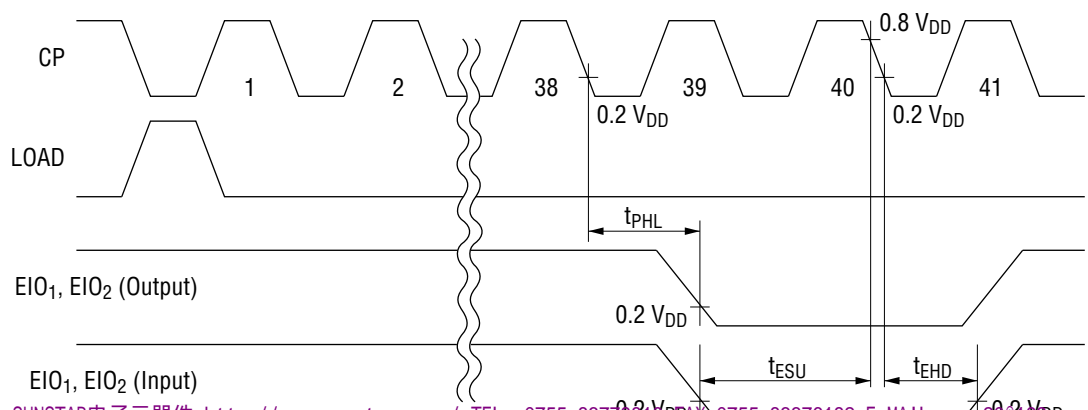
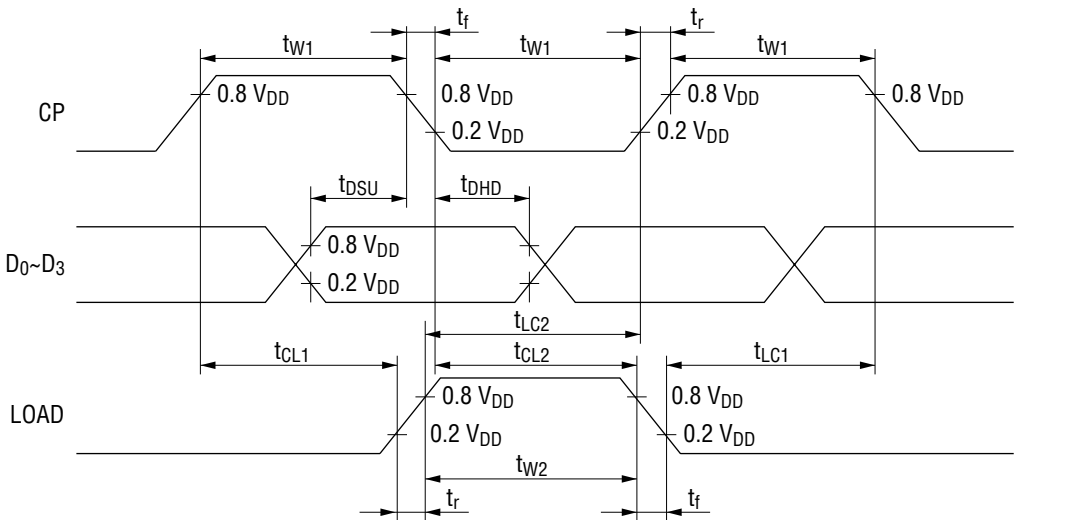

FUNCTIONAL DESCRIPTION

Pin Descriptions

V_{DD}, V_{SS}

Power supply for the device. V_{DD} is set to 2.7 V to 5.5 V. V_{SS} is set to 0 V.

V_{1L}, V_{1R}, V_{3L}, V_{3R}, V_{4L}, V_{4R}, V_{EE}L, V_{EE}R

Bias power supply for the LCD drive voltages. Power supply should be V_{DD} ≥ V₁ > V₃ > V₄ > V_{EE}.

DISPOFF

Input for controlling the output level of O₁ to O₁₆₀. The V₁ level is output from O₁ to O₁₆₀ pins during "L" level input. Refer to Truth Table.

DF

Input for LCD drive wave form AC synchronization.

O₁~O₁₆₀

LCD drive outputs that correspond to each bit of the latch (II). Depending on the combination of the contents of the latch (display data) and DF signal, one of 4 levels (V₁, V₃, V₄, V_{EE}) is output. Refer to Truth Table.

CP

Clock pulse input for display data reading. Data is taken into the latch (I) at the falling edge of the clock pulse.

Use an even number for the clock number per line (the number of the clock pulses during the period from Load input to the next Load input).

EIO₁, EIO₂

Chip Select Signal Input/Output. Input/Output are controlled by the SHL input. If the SHL input at "L" level, EIO₁ is output and EIO₂ is input. If the SHL input is at "H" level, EIO₁ is input and EIO₂ is output. If the SHL is at "L" level, the first EIO₂ is fixed to "L" level, and the following EIO₂ is connected to the preceding EIO₁. If the SHL is at "H" level, the first EIO₁ is fixed to "L" level, and the following EIO₁ is connected to the preceding EIO₂ as shown below.

When SHL is at "L" level

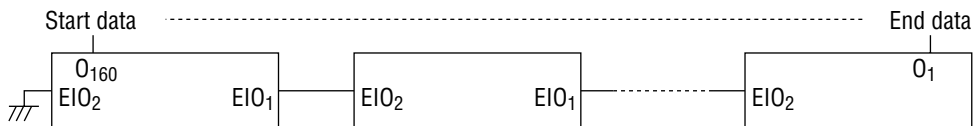

When SHL is at "H" level

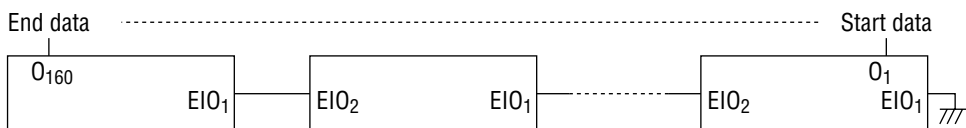

D₀, D₁, D₂, D₃

These are display data inputs that input data with clock synchronization. The table below shows the relationship between the LCD output for the display data and DFs and the LCD.

Display Data	DF	LCD drive output	LCD
L	L	Non-selection level (V ₃)	OFF
H	L	Selection level (V ₁)	ON
L	H	Non-selection level (V ₄)	OFF
H	H	Selection level (V _{EE})	ON

LOAD

This is an input to simultaneously output the display data of one line stored in the latch (I). At the falling edge, the data in the latch (I) is transferred to the latch (II) end is output.

SHL

Input to select for display data reading direction. Input of "L" level at V_{SS} level fetches data in the direction from O₁₆₀ to O₁ sequentially, while input of "H" level at V_{DD} fetches data in the direction from O₁ to O₁₆₀. The table below shows the relationship between read data and driver outputs (O₁ to O₁₆₀).

SHL	EIO ₁	EIO ₂	Data input	Numbers of the clock pulse						
				40 clocks	39 clocks	38 clocks	...	3 clocks	2 clocks	1 clocks
L	Outputs	Inputs	D ₀	O ₁	O ₅	O ₉	...	O ₁₄₉	O ₁₅₃	O ₁₅₇
			D ₁	O ₂	O ₆	O ₁₀	...	O ₁₅₀	O ₁₅₄	O ₁₅₈
			D ₂	O ₃	O ₇	O ₁₁	...	O ₁₅₁	O ₁₅₅	O ₁₅₉
			D ₃	O ₄	O ₈	O ₁₂	...	O ₁₅₂	O ₁₅₆	O ₁₆₀
H	Inputs	Outputs	D ₀	O ₁₆₀	O ₁₅₆	O ₁₅₂	...	O ₁₂	O ₈	O ₄
			D ₁	O ₁₅₉	O ₁₅₅	O ₁₅₁	...	O ₁₁	O ₇	O ₃
			D ₂	O ₁₅₈	O ₁₅₄	O ₁₅₀	...	O ₁₀	O ₆	O ₂
			D ₃	O ₁₅₇	O ₁₅₃	O ₁₄₉	...	O ₉	O ₅	O ₁

TRUTH TABLE

DF	Display Data	DISPOFF	Driver output (O ₁ ~O ₁₆₀)
L	L	H	V ₃
L	H	H	V ₁
H	L	H	V ₄
H	H	H	V _{EE}
X	X	L	V ₁

X : don't care

NOTES ON USAGE (when turning the power ON or OFF)

If a high voltage is applied to a LCD drive system while the logic supply is floating, over-current may destroy the device, because the voltage over the LCD drive system is high.

Follow the sequence below when turning the power ON or OFF.

Power ON : Logic system ON → LCD drive system ON, or both ON

Power OFF : LCD drive system OFF → logic system OFF, or both OFF