



MSM7731-01 Evaluation Board User's Manual

1. General Descriptions

This is a user's manual for OKI Noise/Echo Canceller, MSM7731-01.

The evaluation board is designed for your 'turn-key' evaluation of MSM7731-01 with the following features;

- **On-board Micro Controller Interface Circuit**

Easy to set the internal control register without an external micro controller.

- **On-board Speaker Amplifier and Microphone Input Circuit**

Realizes direct connection to a speaker and a microphone.

- **Single 12V power supply**

For easy connection to a cigarette AC adopter of a car

For the specifications and the functions of MSM7731-01, please refer to the device datasheet.

2. What Consists MSM7731-01 Evaluation Kit

- Evaluation Board (10.5 × 7 inch) ----- Photo.1 shows Photograph (Top View) of Board
- User's Manual (this document)

3. Board Schematics

Figure. 1 shows the schematic of the evaluation board.

4. Functional Descriptions

4-1. Power Supply

Single +12V power supply.

Speaker amplifier operates at 5V, and all the other devices including MSM7731-01 operates at 3V.



4-2. Port Control Interface

MSM7731-01 is designated to be set its device state either from the ports or from an MCU.

When evaluating MSM7731-01 with this evaluation board in port control mode, you should set/change the device state by manipulating on-board switches (DSW1 ~ DSW5).

4-3. MCU (Micro Controller Unit) Interface

MSM7731-01 is designated to be set its device state either from the ports or from an MCU.

When evaluating MSM7731-01 with this evaluation board in MCU control mode, you can further choose whether you would utilize on-board MCU or you would try an external MCU you'll prepare by yourself,

4-3-1. On-board MCU Control

The descriptions hereunder explain the procedures for on-board MCU control;

a) On-board Switches

Set all of DSW6 to "ON".

b) CR WRITE

- Set D7~D0 (SWITCH : SW2 ~ SW9) and A3~A0 (SWITCH : SW14~SW17) to appropriate values referring to the device datasheet.
- set R/W (SWITCH : SW18) to "W".
- Set SET (SWITCH : SW19) "ON".

c) CR READ (for reconfirmation of CR values)

- Set D7~D0 (SWITCH : SW2~SW9) and A3~A0 (SWITCH : SW14~SW17) to appropriate values referring to the device datasheet.
- Set R/W (SWITCH : SW18) to "R".
- Set SET (SWITCH : SW19) "ON".
- Your set CR values are now displayed on LED2~LED9.

4-3-2. External MCU Control

The descriptions hereunder explain the procedures for external MCU control;

a) Set all of DSW6 to "OFF".

b) Connect external the port of your MCU to TP4 (connected to DEN, DIN, DOUT, EXCK pins of MSM7731-01).



4-4. Analog Interface

This board has 4 input/output jacks;

- **MIC**

Acoustic side microphone input.

This is connected to AIN pin of MSM7731-01.

RV1 is variable register control for adjusting input gain.

- **SP**

Acoustic side speaker output.

This is connected to on-board speaker amplifier LM4861 : National Semiconductor (U13).

LM4861 input is connected to AOUT pin of MSM7731-01.

RV4 is variable register control for adjusting output gain.

Be careful **NOT** to saturate the input level of LM4861.

LM4861 device is 1W and 8 ohm load performance.

- **MIN**

Line side analog input.

This is connected to LIN pin of MSM7731-01.

RV2 is variable register control for adjusting input gain.

- **MOUT**

Line side analog output.

This is connected to LOUT pin of MSM7731-01.

RV5 is variable register control for adjusting output gain.

[Note] U15 are reserved for additional amplifiers (+5V).

4-5. Digital Interface

As line-side interface, MSM7731-01 provides you not only digital interface but also analogue interface such as for IS-95 handsets. When you like to utilize this digital line-side interface provided with MSM7731-01, connect the external digital interface to TP3 (SYNC, BCLK, PCMI, PCMEI, PCMO, PCMEI pins of MSM7731).

JUMPER JP1 and JP2 are on-board pull-up/pull-down control.

("0" = pull-down ; "1" = pull-up ; "Remove JPx" = no pull-up/pull-down)

4-6. Clock Input

On board 19.2MHz X'tal is available.

[Note] XL1 is reserved for an oscillator.



Figure 1 Board Schematic (1/3)

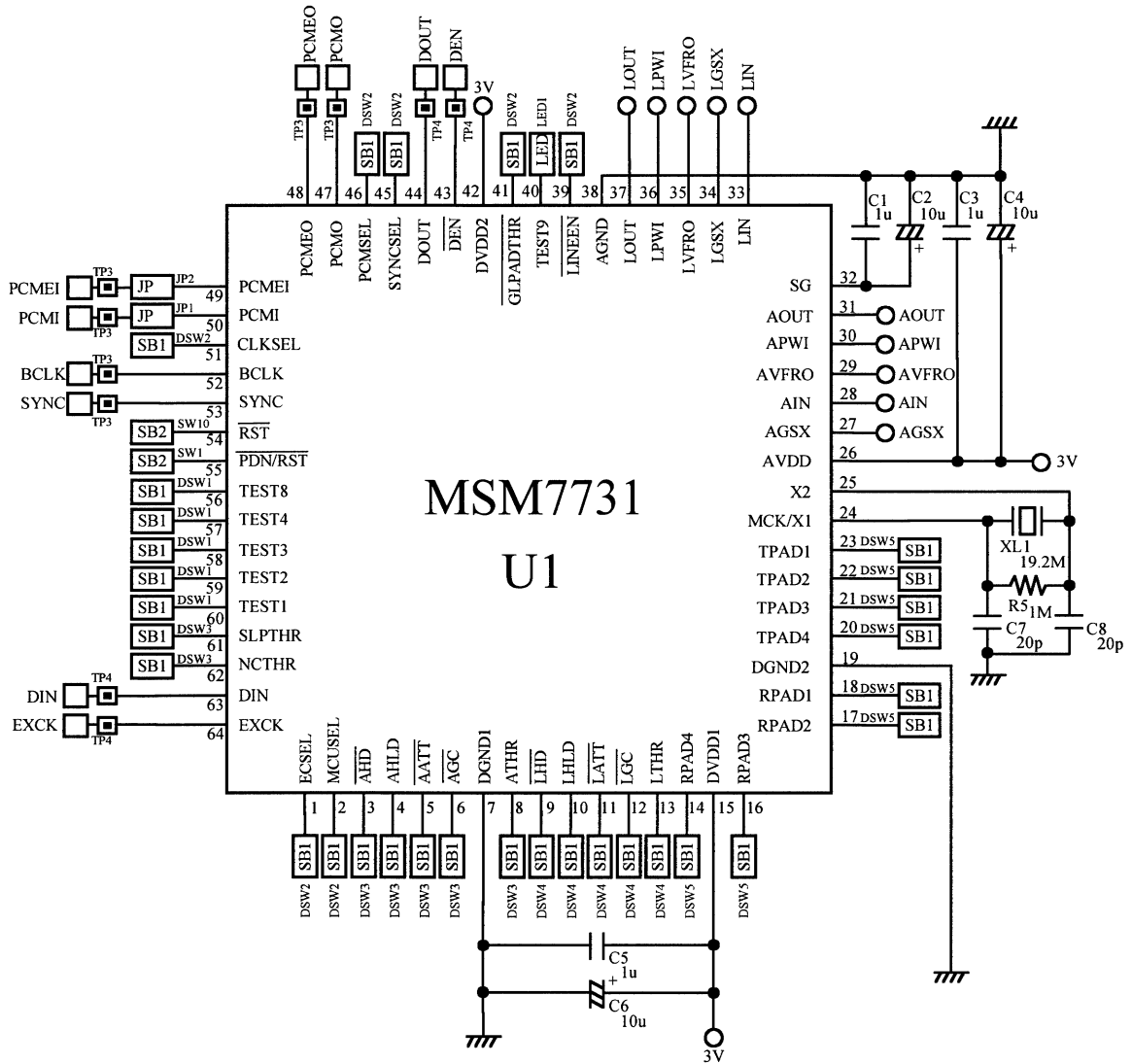
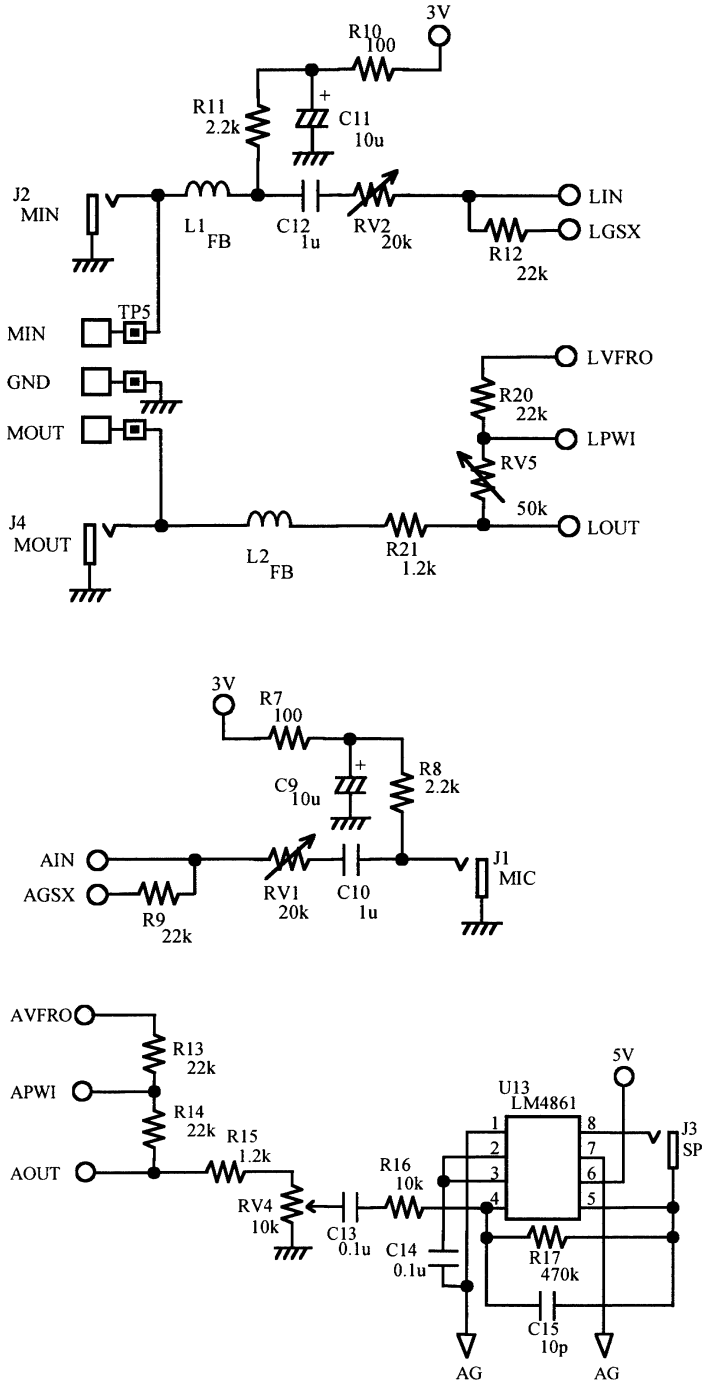
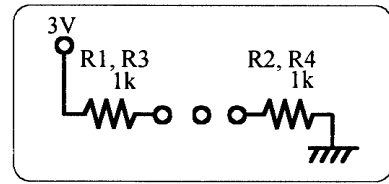



Figure 1 Board Schematic (2/3)



JP



LED

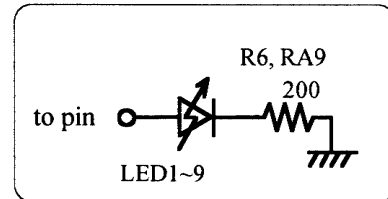

SB1 slide-type switch

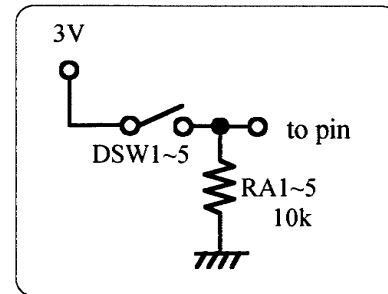

SB2 snap-type switch SB3 toggle-type switch

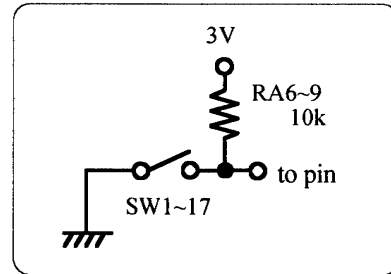

SB4 slide-type switch

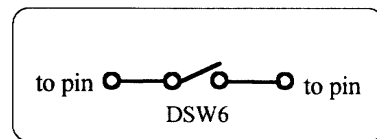
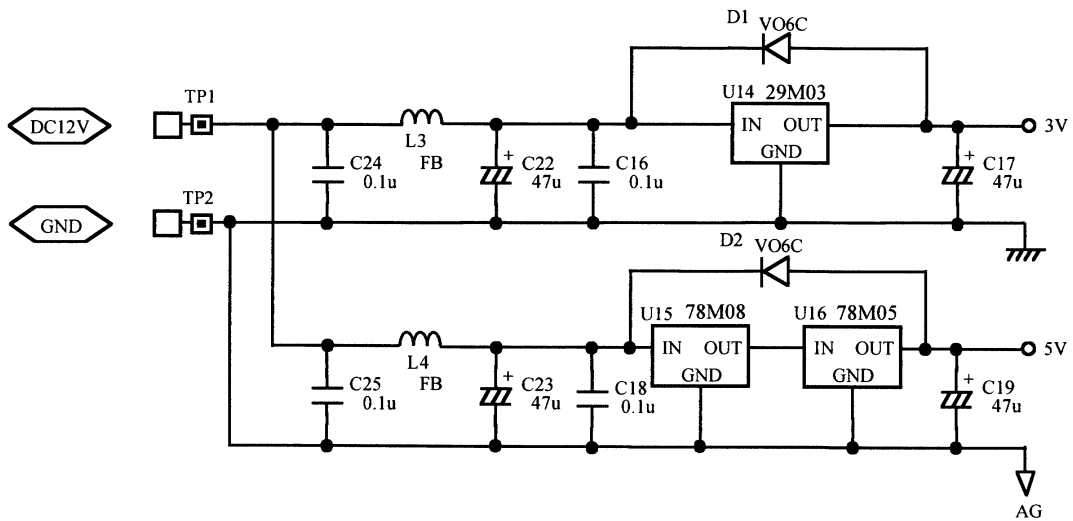
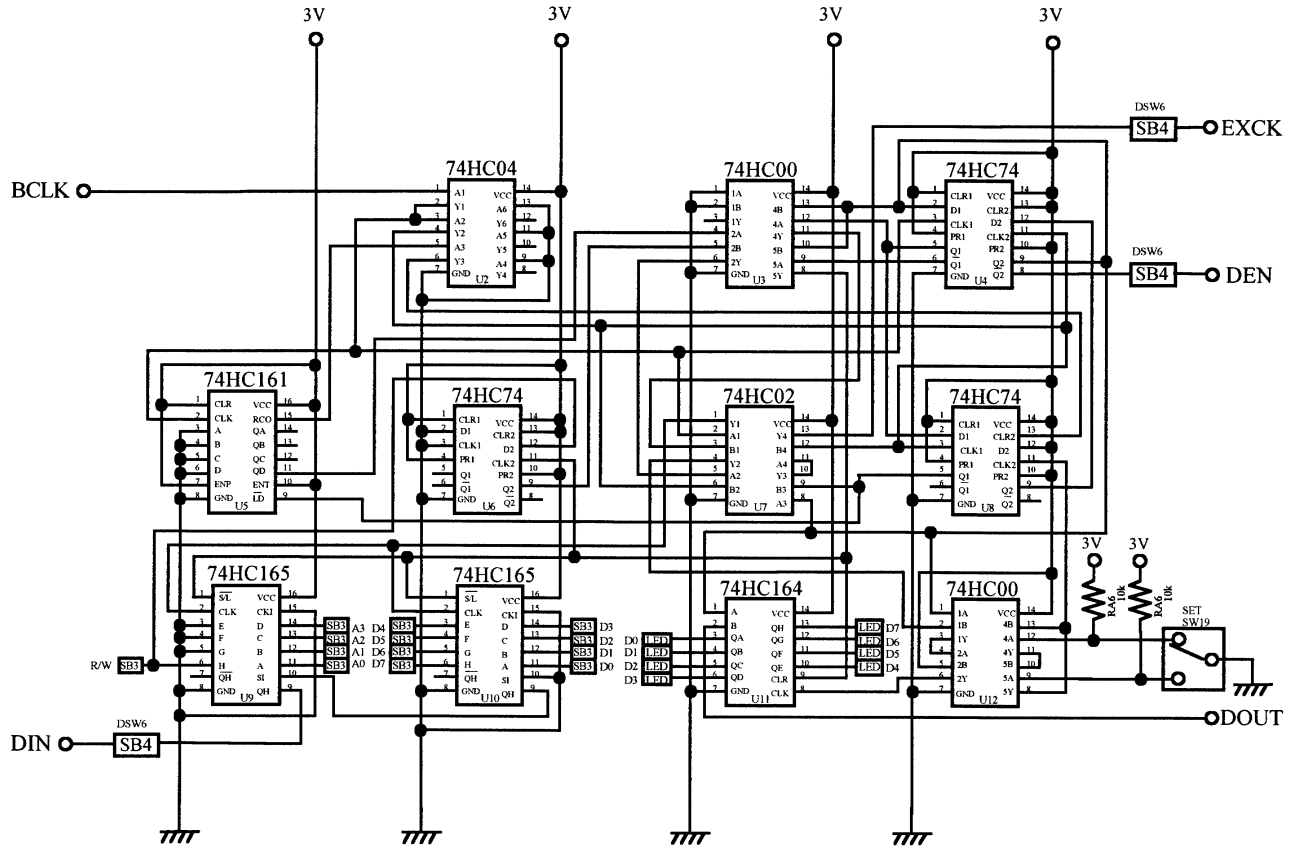



Figure 1 Board Schematic (2/3)



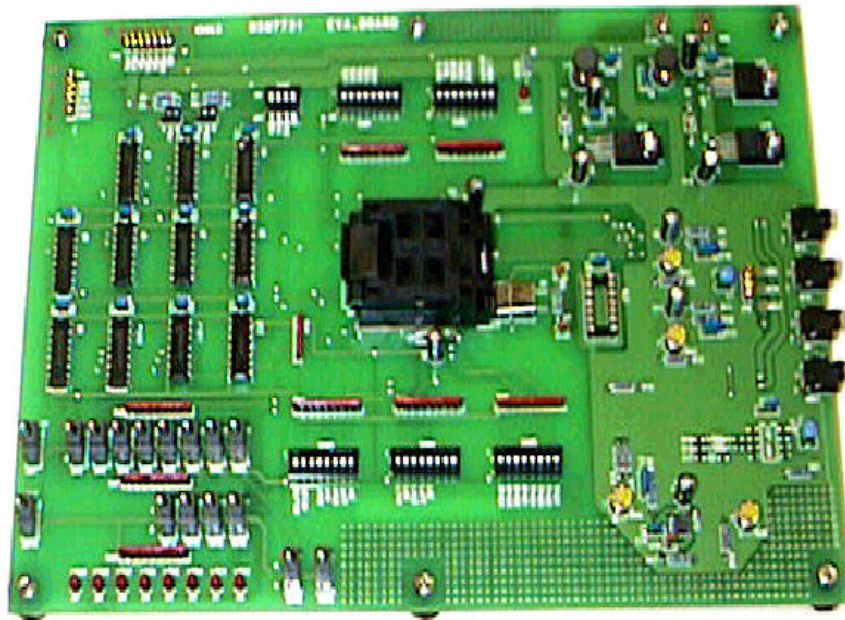

Photo.1 Photograph of the board (Top Vies)