

OKI electronic components

OL695N-20/AP10

1.625 μm High-Power Laser-Diode Coaxial Module

GENERAL DESCRIPTION

The OL695N-20/AP10 is an extremely high-power MQW structured 1.625 μm laser-diode coaxial module with a single-mode fiber pigtail. This module is an optimal light source for optical measuring instruments and other systems that require high power.

FEATURES

- High output power: Pf=20 mW (Pulse)
- Single-mode fiber
- Multi-quantum-well (MQW) structure

APPLICATIONS

- Optical measuring instruments
- OTDRs

PACKAGE DIMENSIONS (Unit: mm)

- OL695N-20/AP10

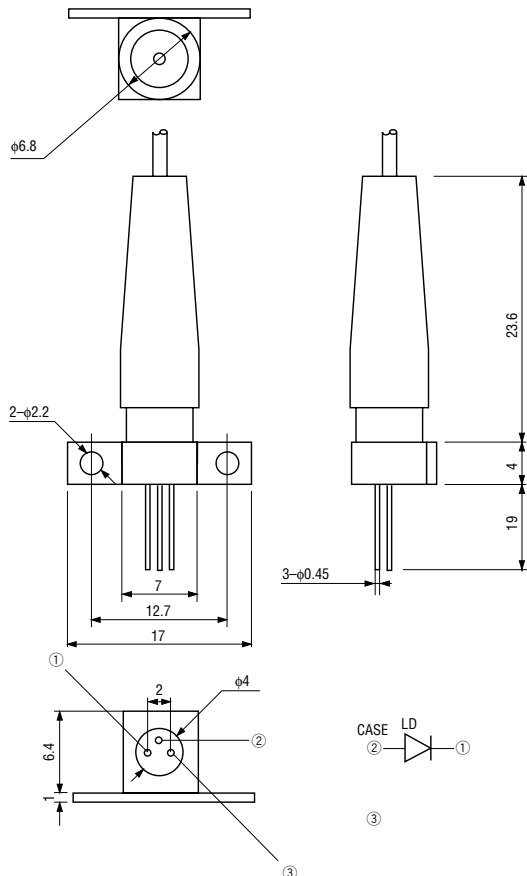

ABSOLUTE MAXIMUM RATINGS

Parameter	Symbol	Test Conditions	Ratings		Unit
Fiber Output Power	Pf	Ta=25°C	OL695N-20/AP10	30	mW
LD Reverse Voltage	V _R (LD)		2		V
Operating Temperature	T _{opr}	—	-20 to +60		°C
Storage Temperature	T _{stg}	—	-40 to +85		°C

OPTICAL AND ELECTRICAL CHARACTERISTICS

Parameter	Symbol	Test Conditions	Min.	Typ.	Max.	Unit
Threshold Current	I _{th}	—	—	—	100	mA
Center Wavelength	λ _c	—	1615	1625	1635	nm
Spectral Width	σ	RMS	—	—	10	nm

Optical Output Power (Pf)

Model	Test Conditions	Min.	Typ.	Max.	Unit
OL695N-20/AP10	I _F =650 mA (Pulse*)	20	—	—	mW

*Pulse Condition : Width 10 μs, duty ratio : 1%

TYPICAL CHARACTERISTICS

● OL695N-20/AP10

Fiber Output Power vs. Forward Current

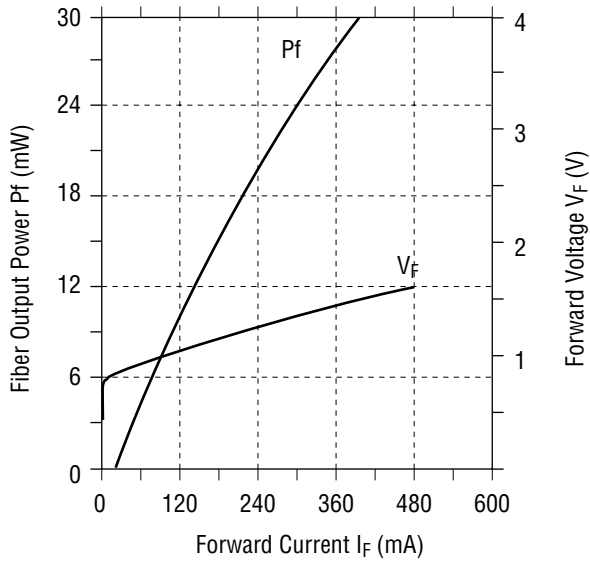

● OL695N-20/AP10

Oscillation Spectrum (T_a=25°C)

