

Data Sheet



SCA820-D03 SINGLE AXIS ACCELEROMETER WITH DIGITAL SPI INTERFACE

Features

- 3.3V supply voltage
- ± 2 g measurement range
- Single axis measurement in Z direction
- ± 70 mg offset accuracy over temp range
- SPI digital interface
- Enhanced self diagnostics features
- Size 7.6 x 3.3 x 8.6 mm (w x h x l)
- Qualified according to AEC-Q100 standard
- Package, pin-out and SPI protocol compatible with Murata digital accelerometer product family
- RoHS compliant Dual Flat Lead (DFL) plastic package suitable for lead free soldering process and SMD mounting
- Proven capacitive 3D-MEMS technology

Applications

SCA820-D03 is targeted to automotive applications with high stability requirements. Typical applications include

- Electronic Stability Control (ESC)
- Electronic Parking Brake (EPB)
- Hill Start Aid (HSA)
- Roll Over
- Suspension
- Inclination
- Industrial applications

General Description

SCA820-D03 is a single axis accelerometer component based on Murata capacitive 3D-MEMS technology. The component integrates high accuracy micromechanical acceleration sensing together with a flexible SPI digital interface. Dual Flat Lead (DFL) housing of the component guarantees robust operation over the product lifetime.

SCA820-D03 is designed, manufactured and tested for high stability, reliability and quality requirements of automotive applications. The accelerometer has extremely stable output over wide range of temperature, humidity and mechanical noise. The component is qualified against AEC-Q100 standard and has several advanced self diagnostics features. The DFL housing is suitable for SMD mounting and the component is compatible with RoHS and ELV directives.

SCA820-D03 is a part of Murata digital accelerometer family and fully compatible with single axis accelerometers (SCA800 series) and other multi axis accelerometers (SCA2100 series and SCA3100 series).

Performance Characteristics

V_{dd}=3.3 V and ambient temperature unless otherwise specified.

Parameter	Condition				Units
		Min	Typ	Max	
Analog and digital V _{dd}		3.0		3.6	V
Current consumption	Active mode		5	6.3	mA
	Power down mode			0.1	mA
Measurement range	Measurement axis Z	-2		2	g
Operating temperature		-40		125	°C
Offset total error ^{A)}	Temperature range -40 ... +125 °C	-100		100	mg
Offset temperature dependency ^{B)}	Temperature range -40 ... +125 °C	-70		70	mg
Sensitivity	12 bit output		900		Count/g
Total sensitivity error		-4		4	% FS
Linearity error	+1g ... -1g range	-20		20	mg
Cross-Axis sensitivity				±3.5	%
Zero acceleration output ^{C)}	2-complement		0		Counts
Amplitude response	-3dB frequency	30		80	Hz
Noise				5	mg RMS
Power on setup time				0.1	s
Output data rate			1000		Hz
Output load				50	pF
SPI clock rate				8	MHz
ESD protection	Human Body Model			4	kV
	Charge Device Model			1	kV
Moisture sensitivity level	IPC/JEDEC J-STD-020C, Level 3				
Mechanical shock				20 000	g

A) Includes offset deviation from 0g value including calibration error and drift over lifetime, temperature and supply voltage.

B) Offset drift due to temperature. Value is a relative value and has not to be centered to zero.

C) See Figure 3

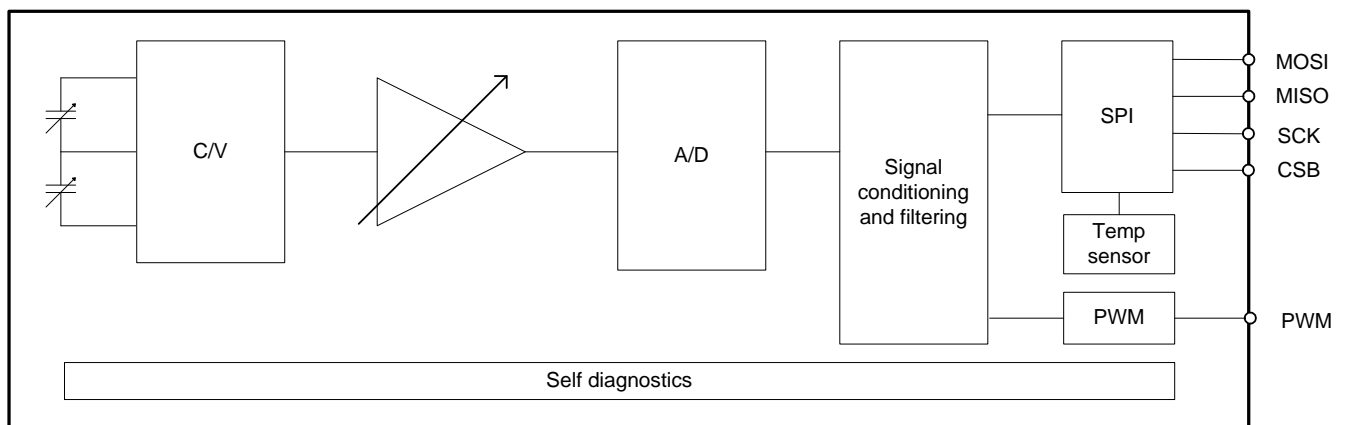

Figure 1. SCA820-D03 Block diagram

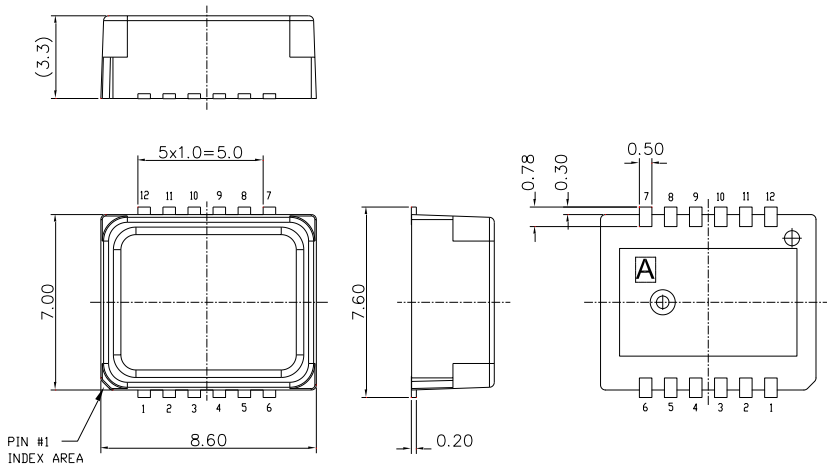

Figure 2. Housing dimensions



Figure 3. Accelerometer measuring directions

Zero acceleration output position



Document Change Control

Rev.	Date	Change Description
A	07.10.06	Preliminary version
B	08.08.07	Frequency response changed from 40-60 Hz to 30-80 Hz