

Digital Test Stand Electronics System

Type 5633A2

for Tire Test Stands for RoaDyn® S220 and S260 Measuring Hubs

The digital test stand electronics system Typ 5633A2 is used in combination with RoaDyn S220 and S260 measuring hubs for instrumenting tire test stands. The individual measuring hub signals are amplified, digitalized and output as F_x and F_z . The signals F_x and F_z are output as CAN or analog signal.

- Digital test stand electronics system for RoaDyn measuring hubs
- 16 channel
- Signal output ± 10 VDC per channel
- F_x and F_z as CAN or analog signal

Description

The measuring chain typically consists of measuring hub, connecting cable and digital test stand electronics system Type 5633A2. The 16 channel designs allow connection of measuring hubs with different numbers of load cells.

The digital test stand electronics system is mounted with four screws in an environment within the specifications. The system is connected to the measuring hub with connecting cable Type 1795A14. It is connected to the customer's data acquisition system with an included D-Sub 37 pole pos. connector without cable to allow custom assembly.

A suitable power cable with two laboratory connectors is also included for the power supply. The digital test stand electronics system is set up via an RS-232C interface.

Technical Data

Power supply	VDC	10 ... 28
Max. power consumption	W	12
Operating temperature range	°C	0 ... 50
Max. relative humidity (non-condensing)	%	<80
Weight	kg	1,0
Dimensions	mm	170x140x50
Degree of protection		IP40
Power connector		Lemo EGG.1B.302.CLL



Data Input

Channels(max.)	number	16
Connector	sensor input 1	Lemo EGG.2B.326.CLN
Connector	sensor input 2	Lemo EGG.2B.326.CLN

Data Output

Channels	number	3
CAN output	F_x	CAN V2.0B
	F_z	CAN V2.0B
	temp.	CAN V2.0B
Sampling rate	Hz	250
Delay	ms	<3
Resolution	bit	16
Analog output	F_x	V ± 10 VDC
	F_z	V ± 10 VDC
	temp.	V ± 10 VDC
Connector		D-Sub 37 pol. neg.
Max. length of connecting cable CAN-Bus (@ 1 Mbit/s)	m	40
Max. length of connecting cable analog	m	25



Fig. 1: Hub connection end

Dimensions

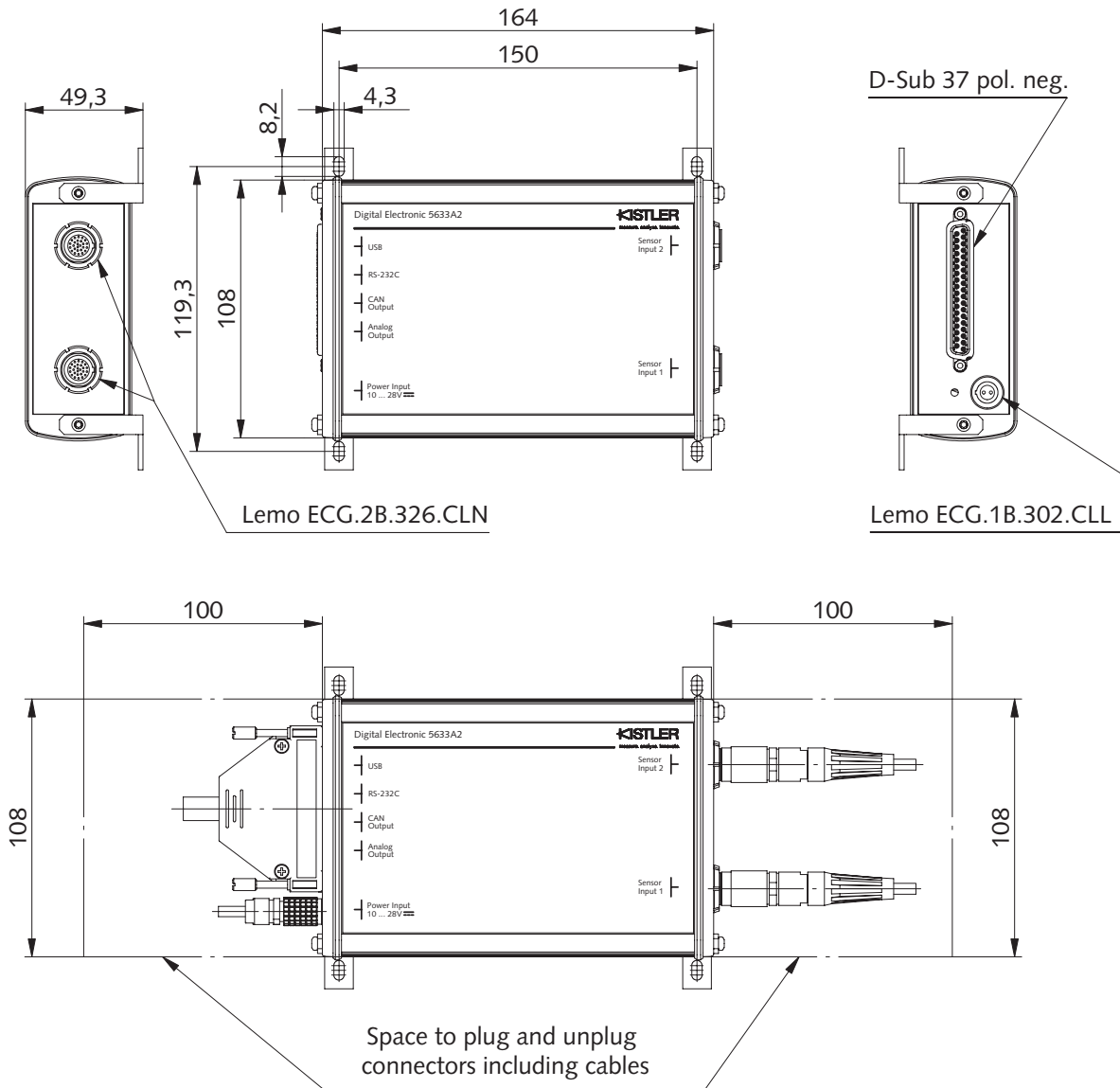

Fig. 2: Dimensions digital test stand electronics system Type 5633A2

5633A2_000-980e-12.11

Included Accessories

- Power cable, l = 10 m (Lemo – 2 x laboratory connectors)
- Connector: D-sub 37-pole pos. without cable to allow custom assembly

Type/Art. No.

- 65009982
- 65016032

Ordering Code

- Digital test stand electronics for tire test stands for RoaDyn S220 and S260 measuring hubs

Type 5633A2

Optional Accessories

- Hub connection cable, l = 4 m, with straight connector

Type/Art. No.

- 1795A14

This information corresponds to the current state of knowledge. Kistler reserves the right to make technical changes. Liability for consequential damage resulting from the use of Kistler products is excluded.

©2011, Kistler Group, Eulachstrasse 22, 8408 Winterthur, Switzerland
 Tel. +41 52 224 11 11, Fax +41 52 224 14 14, info@kistler.com, www.kistler.com
 Kistler is a registered trademark of Kistler Holding AG.