



TGS 3870 - for the detection of both Methane and Carbon Monoxide

Features:

- * Miniature size and low power consumption
- * High sensitivity and selectivity to both methane and carbon monoxide (CO)
- * Low sensitivity to alcohol vapor
- * Long life and low cost

Applications:

- * Combination methane and carbon monoxide detectors

TGS 3870 is Figaro's new metal oxide semiconductor gas sensor for the detection of both methane and carbon monoxide. Using a micro-bead gas sensing structure, both methane and carbon monoxide can be detected with a single sensor element by periodic application of two different heater voltages (high and low). Miniaturization of the gas sensing bead results in a heater power consumption of only 38mW (average).

TGS 3870 has low sensitivity to alcohol vapors (a typical interference gas in the residential environment) and has high durability, making the sensor ideal for consumer market gas alarms.



The figure below represents typical sensitivity characteristics, all data having been gathered at standard test conditions (see reverse side of this sheet). The Y-axis is indicated as sensor resistance ratio (R_s/R_o) which is defined as follows:

- R_s = Sensor resistance in displayed gases at various concentrations
- R_o = Sensor resistance in 3000ppm of methane

Sensitivity Characteristics (methane):

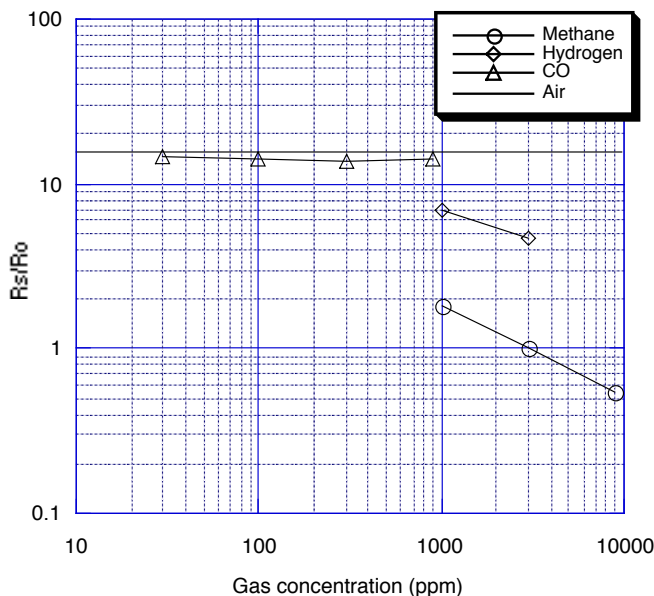

The figure below represents typical sensitivity characteristics, all data having been gathered at standard test conditions (see reverse side of this sheet). The Y-axis is indicated as sensor resistance ratio (R_s/R_o) which is defined as follows:

- R_s = Sensor resistance in displayed gases at various concentrations
- R_o = Sensor resistance in 100ppm of CO

Sensitivity Characteristics (CO):

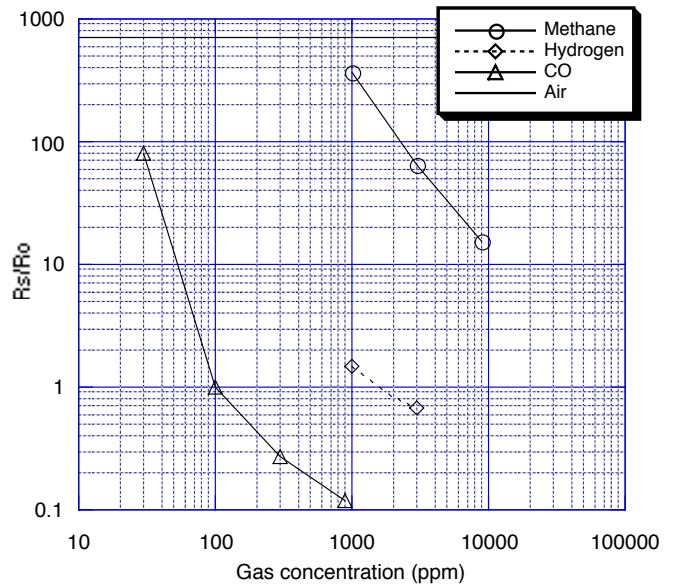

IMPORTANT NOTE: OPERATING CONDITIONS IN WHICH FIGARO SENSORS ARE USED WILL VARY WITH EACH CUSTOMER'S SPECIFIC APPLICATIONS. FIGARO STRONGLY RECOMMENDS CONSULTING OUR TECHNICAL STAFF BEFORE DEPLOYING FIGARO SENSORS IN YOUR APPLICATION AND, IN PARTICULAR, WHEN CUSTOMER'S TARGET GASES ARE NOT LISTED HEREIN. FIGARO CANNOT ASSUME ANY RESPONSIBILITY FOR ANY USE OF ITS SENSORS IN A PRODUCT OR APPLICATION FOR WHICH SENSOR HAS NOT BEEN SPECIFICALLY TESTED BY FIGARO.

Basic Measuring Circuit:

The sensor requires two voltage inputs: heater voltage (V_H) and circuit voltage (V_C). The sensor has three pins: Pin #3--heater (+), Pin #2--sensor electrode (+), and Pin #1--common (-). To maintain the sensing element at specific temperatures which are optimal for sensing two different gases, heater voltages of 0.9V and 0.2V are alternately applied between pins #1 and #3 during a 20 second heating cycle.

Circuit voltage (V_C) is applied between both ends of the sensor (R_S) and a load resistor (R_L), which are connected in series, to allow measurement of voltage (V_{RS}).

Circuit voltage (V_C) should be applied only at the moment when the signal is taken from the sensor.

Please refer to the document "Technical Information for TGS3870" for details regarding the timing and application of V_C and V_H.

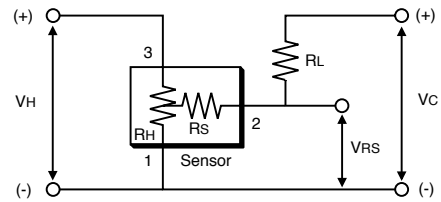

Basic measuring circuit

Caution: Do not apply a constant circuit voltage (5.0V) or the sensor would not exhibit its specified characteristics.

Specifications:

Model number		TGS 3870	
Sensing element type		Micro-bead	
Standard package		Plastic base and metal can	
Target gases		Methane and Carbon Monoxide	
Typical detection range		Methane - 500~12500 ppm Carbon monoxide - 50~1000ppm	
Standard circuit conditions	Heater Voltage	V _H	V _{HH} = 0.9V±3%, 5 sec. V _{HL} = 0.2V±3%, 15 sec.
	Circuit voltage	V _C	5.0±0.2V DC pulse <i>(refer to Technical Information for TGS3870)</i>
	Load resistance	R _L	Variable (>0.75kΩ)
Electrical characteristics under standard test conditions	Heater resistance	R _H	3±0.3Ω at room temp.
	Heater power consumption	P _H	120mW V _{HH} = 0.9V DC
			11mW V _{HL} = 0.2V DC
			38mW average
	Sensor resistance	R _S	0.35~3.5kΩ in 3000ppm methane 1.8~24kΩ in 150ppm CO
Sensitivity (Change ratio of R _S)	β	0.50~0.65 R _S CH ₄ 3000ppm R _S CH ₄ 1000ppm	
		0.1~0.6 R _S CO 300ppm R _S CO 150ppm	
Standard test conditions	Test gas conditions	Target gas in air at 20±2°C, 65±5%RH	
	Circuit conditions	V _{HH} = 0.9V±2%V, 5 sec. V _{HL} = 0.2V±2%V, 15 sec. V _C = 5.0±0.2V DC pulse <i>(refer to Technical Information for TGS3870)</i>	
	Conditioning period before test	≥5 days	

Structure and Dimensions:

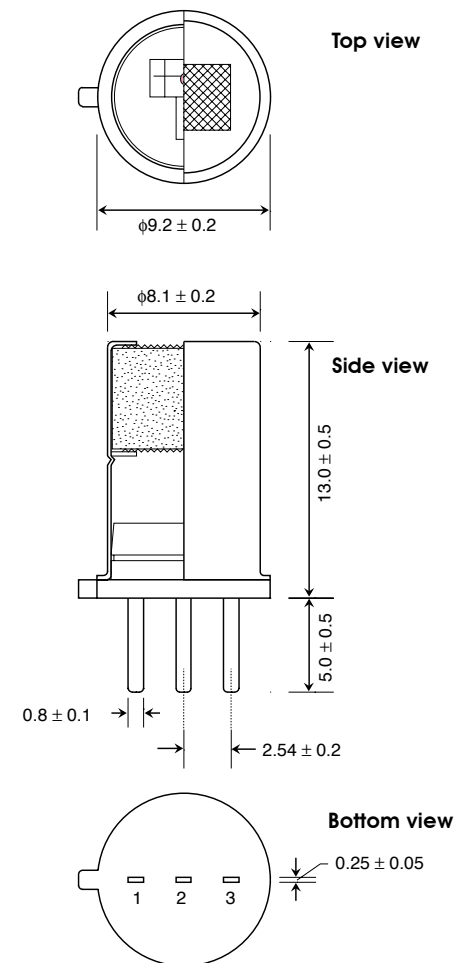

Pin connection:
1: Common(-)
2: Sensor electrode(+)
3: Heater(+)

unit:mm

The value of power dissipation (P_S) can be calculated by utilizing the following formula:

$$P_S = \frac{(V_{RS})^2}{R_S}$$

Sensor resistance (R_S) is calculated with a measured value of V_{RS} by using the following formula:

$$R_S = \frac{(V_{RS} - 0.5V_H)}{(V_C - V_{RS})} \times R_L$$

For information on warranty, please refer to Standard Terms and Conditions of Sale of Figaro USA Inc. All sensor characteristics shown in this brochure represent typical characteristics. Actual characteristics vary from sensor to sensor. The only characteristics warranted are those in the Specification table above.

FIGARO USA, INC.
121 S. Wilke Rd. Suite 300
Arlington Heights, IL 60005
Phone: (847)-832-1701
Fax: (847)-832-1705
email: figarousa@figarosensor.com