

DISOMAT® T Weigh Transmitter



- Digital weigh transmitter
- Single-ingredient feed control
- System-compatible through serial interface, analog output and binary inputs/outputs
- Suitable for multi-scale systems through small design and fieldbus interfaces
- Convenient commissioning via PC using DISOPLAN T program
- Four 230 V~ relay outputs
- 3 binary inputs
- High degree of safety through safe isolation and EMC
- Optional weight display
- Variant for connection of scales in explosion-hazard areas

Application

Designed as favourably priced solution for many standard weighing tasks, the DISOMAT® T Weigh Transmitter is used as weight value transducer for weight value monitoring, hopper level measurement and control of single-ingredient feed operations.

Combined with load cells, DISOMAT T is also suitable for sophisticated measuring tasks.

Used in conjunction with Schenck measuring eyes of the DMA type, the system is a simple and far less costly answer to applications where more approximate measurement will suffice, e.g. hopper level measurement.

Equipped with analog output and serial interface, DISOMAT T is suitable for all remote-controlled scales connected to higher level EDP or PLC systems. The optional display enables the weight value to be checked locally.

Equipment

Main board DWT 100 comprises the following functions:

- Measuring circuit with A/D converter
- 4 relay outputs, safety-separated
- 3 binary inputs, galvanically isolated
- 1 analog output
- Service interface
- EDP interface (various protocols)

Expansion boards provide additional functions:

- PROFIBUS interface via PROFIBUS board VPB 20100
- DeviceNet interface via coupler board VCB 010
- Display, 3 1/2-digit, 10 mm digit height to control the scales function.
- 3 buttons to control the scales function.

DISOMAT T is supplied as plug-in board or mounted in a 19" rack or fieldbox.

Appropriate designs of the DISOMAT T are available for explosion-hazard areas of categories 2D/3G for direct on-site installation. Weighing sensors and displays in category 2G (zone1) are connected via the optional barrier sets DXB 10x.

The barrier sets are mounted directly into the field housings or inserted into the 19" rack.

Functions

DISOMAT T comes with various EDP protocols. In addition, it can be integrated into commercial fieldbus systems (J-BUS, PROFIBUS, DeviceNet).

Four relay outputs are available for limit value monitoring, output of status messages or control of feeding process. The inputs can also be used for control of feeding (Start/Stop, Abort) and basic scale functions (Acquire/Clear Tare / Zero Set).

In the DISOMAT T version with display and function keys, the three keys are hardwired to the inputs, i.e. they trigger the functions described.

All inputs/outputs are galvanically isolated; the relay outputs, additionally safety-separated.

All configuration, calibration and diagnosis dialogs are conveniently performed on a PC using the DISOPLAN T Windows program. If no Windows PC is available, DISOMAT T can also be configured using the built-in command line interpreter (TCLI) on a VT terminal or PC with VT emulation.

An on-line help function assists the DISOPLAN T user by providing comprehensive information on all important menu items.

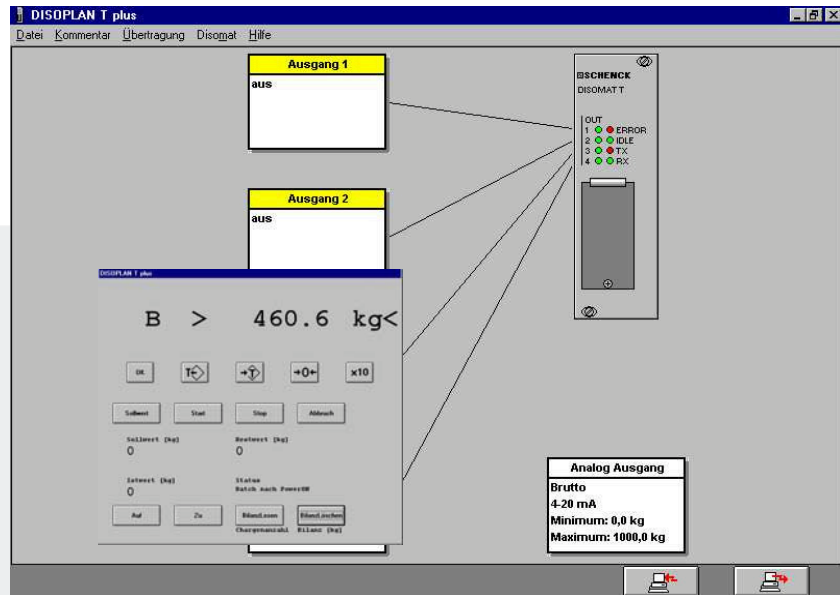

DISOPLAN T with faded-in weight window

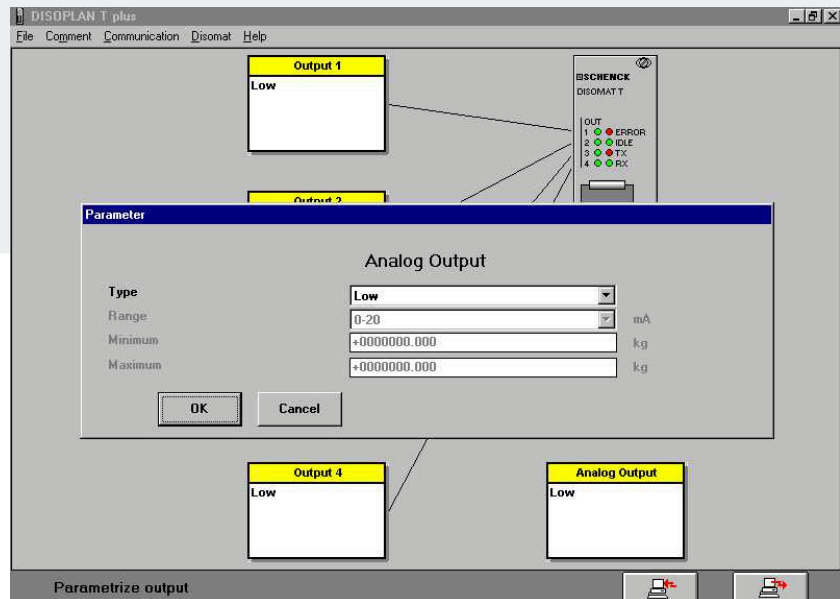

Parameter setting for analog output

Feeding Functions

Despite its compact design and simple parameterisation, the DISOMAT T feeding functions can be set over a wide range.

This allows the feeding process to be matched to almost any task.

The material-independent setting comprises, for instance, the following items:

- Hopper level limit values (Min / Max)
- Refill parameters (pulse duration / control magnitude)
- Time monitoring (batching / refilling / discharge)
- Feed system (fill / discharge weighing)
- Multiple feed operations (setpoint / scale maximum load)
- Automatic / Manual functions
- Outputs on serial display

Scale control		
MIN control level	+000000.00000	kg
MAX control level	+000000.00000	kg
Bumping control magnitude	+00.00	mA
Bumping pulse time	+002.0	sec
Max. batching time	+003600.	sec
Max. fill/discharge time	+000060.	sec
Batching direction	Fill weighing	
Multibatch	No	
Automatic start	No	
Automatic discharge/filling	No	
Binary inputs	SetTare, ClearTare, SetZero	
Secondary Display	Current weight	

Data input for scale control

For every ingredient to be fed, a set of material-specific data can be preset before start of feeding, e.g.

- Pre-act and main contacts
- Full feed and dribble feed control magnitudes (feeding process controlled in analog fashion)
- Tolerance check parameters
- Optimisation

Ingredient data		
Full feed control magnitude	+15.0	mA
Dribble feed control magnitude	+05.0	mA
Negative batch tolerance	+00003.000	kg
Positive batch tolerance	+00003.000	kg
Dribble feed amount (pre-act)	+0000000.000	kg
Dribble feed ramp time	+00.0	sec
Adaption factor	+0.5	
Correction amount (main contact)	+00000.000	kg

Input screen for ingredient data

After setpoint input, feeding can start.

In conjunction with a host control system presetting the relevant ingredient data and setpoints, multi-ingredient feed operations can be realised as well.

Housings

19" Rack DNG 100

(Fig. 1)

designed for control cubicles accessible from the rear or equipped with swivelling frame. DNG 100 can be equipped with 10 main boards. One slot each is required for:

- DWT 100
DISOMAT T as p.c. board
- DXB 101, 102, 103
Ex-protective circuitry
- DNT 300/310, VNT 331
Power supply for 115/230 VAC (only 1 unit per rack)
- Dummy front panel
- The display variant needs two slots.

The optional bus board can do without additional slots.

Front protected to: IP 20
Weight (equipped): apr. 10 kg

Fieldbox DFG

(Fig. 2)

designed for local installation, complete with DWT 100.

Optional equipment:

- DeviceNET expansion board
- Profibus expansion board
- Ex-protective circuitry
DXB 101/102/103
- 115/230 VAC transformer
- Display in cover

Material: Polyester
Protected to: IP 65
Weight: apr. 3 - 4 kg

Dimensions:

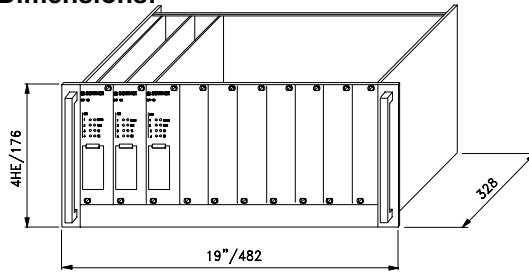

Fig.1
19" Rack DNG 100

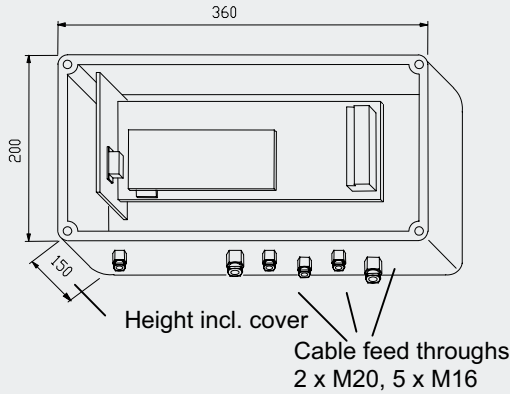
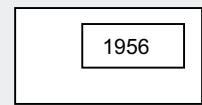

Fig.2
Fieldbox DFG



Optional display in the cover

Fig.3

Weigh Transmitter DWT 100.

Designed with same dimensions:

- Ex-protective circuitry DXB 10x
- Power supplies DNT 300 / 310, VNT 331

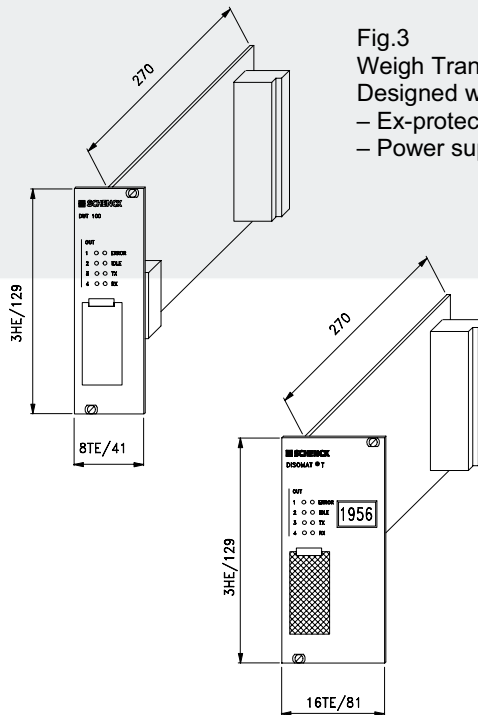

Fig. 4:

Weigh Transmitter

DWT 100-D.

The optional

variant with

3 ½ digit display

(digit height 10

mm) and 3

function keys

occupy two slots in

rack.

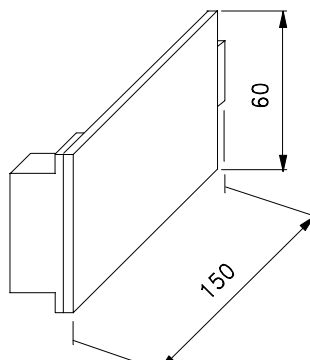

Fig.5

Expansion boards:

- PROFIBUS board DPB V100

- DeviceNet board VCB010

One expansion board can be plugged onto weigh transmitter board DWT 100.

DISOMAT T – Open-ended

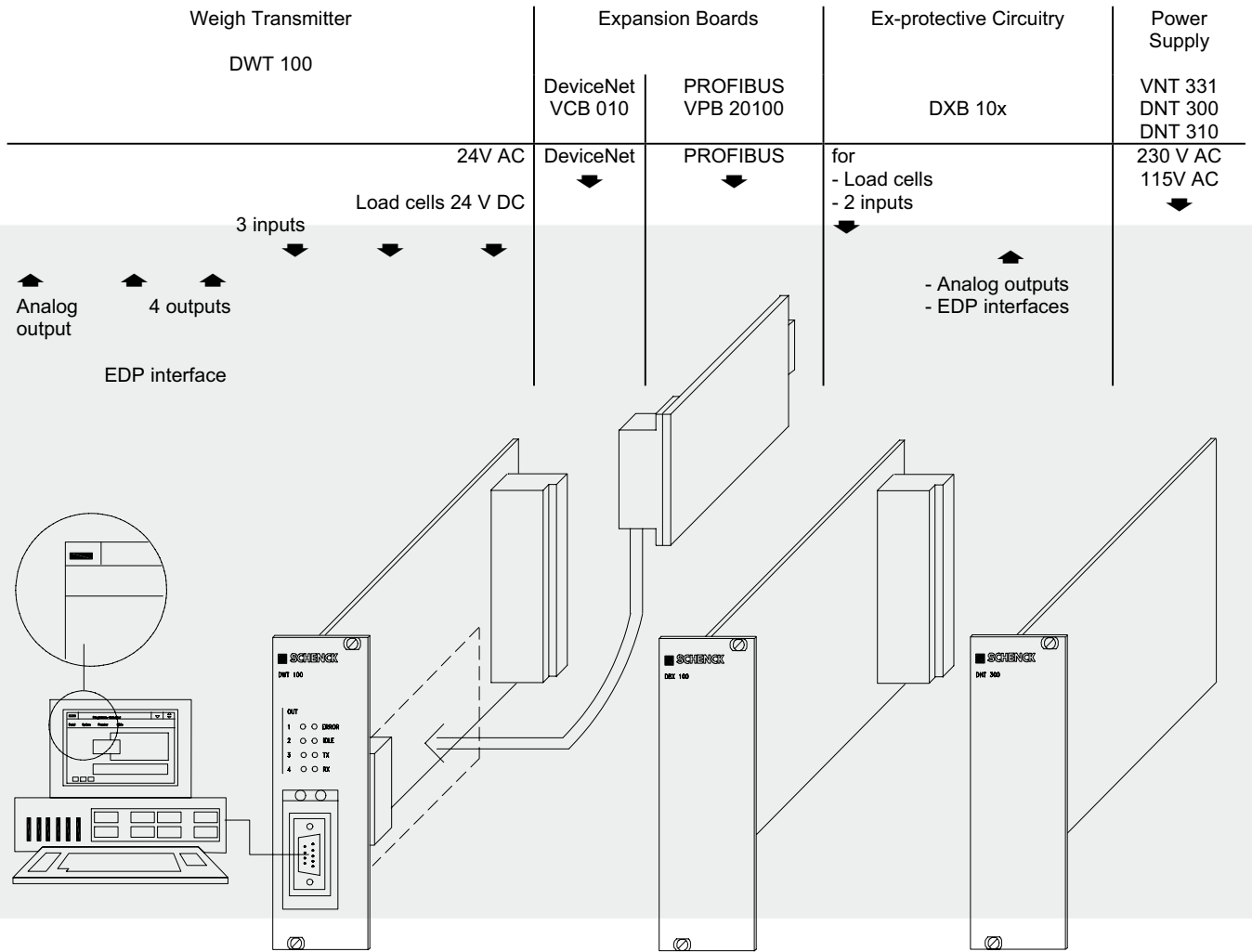

Technical Data

Display	8 LEDs for display of: – Output contact status – Error message – System load Sending/receiving on EDP interface
Load cells	max. 12 x RT load cells max. 4 x 350Ω load cells max. 4 x DMA measuring eyes
Load cell supply	20 and 10 V
Load cell cable	max. 1000 m
Overvoltage protection on measuring input	± 30 V
Measuring circuit accuracy	Linearity: < 0.01 % Range stability: ± 20 ppm/K Zero point stability: ± 1 μV / K basic variant
Number of increments	100 to 50,000
Measuring rate	70 measurement values/sec.
Storage temperature	-10° to +80°C
Operating temperature	-10° to +50°C
Sensitivity	≥ 2 μV/d
Input signal	0.1 to 57 mV
Dead load signal	0 to 57 mV
Required power	18 – 36 VDC or 24VAC +10% –15%, 47 – 63Hz 0.63AT fusing (0.8AT with Profibus board)
Power consumption	apr. 10 W
Data backup	All setting data are stored fail-safe in EEPROM. After power failure, DWT 100 initialises and automatically resumes operating.
Zero setting function	max. 20 %
Automatic zero tracking	0.5 d/s; deselectable
Filter	Software filter 1 to 10 sec.
Line interference suppression	90 dB, 48 to 62 Hz
Common mode rejection	> 110 dB
CE conformity	As per EC directives 89/336 EWG 73/ 23 EWG 90/384 EWG

2 serial interfaces EDP interface	Rear panel equipped with plug-in block terminals. RS 232 (factory set), RS 485 or 20 mA TTY pluggable to EDP, PLC, PC and serial displays. Available protocols: - Siemens 3964 R - Siemens 3964 R for S5 mode - Siemens Teleperm - SCHENCK Protocol in accordance with Spec Sheet DDP 8 785 - J-Bus (MODBUS) - Protocols for secondary displays
Service interface	9-pole SUB-D connector on front panel for connection of PC to DISOPLAN T configuration program. RS 232 with fixed parameter setting: 9600 baud, 8 bits, even parity, 1 stop bit, no handshake
Analog output	0 – 20 mA or 4 – 20 mA 500 Ω maximum load ATTENTION: The use of the optional DISOMAT T display reduces the admissible external load by 250 ohms. When connecting the analog output in the hazardous area, please note the instructions given at the Explosion Protection item. Resolution: 10,000 increments Linearity 0.05% calibrated; 1% non-calibrated. Range stability: < 0.05 % / 10 K Zero point stability: < 0.10 % / 10 K Analog output can be assigned to the following values: - Net - Gross - dW/dt - Preset by EDP Analog output galvanically isolated
Binary outputs	4 relay outputs, 230 V AC/0, 1 A, or 24 V DC/0.5 A, switched as MAX or MIN contact via comparators using the following selectable values: - Net - Gross - dW/dt Controlled directly: - No-motion - Tare acquired - Preset by EDP - Fault - Feed control Binary outputs galvanically isolated and safety-separated (VDE 0160).
Binary inputs	3 inputs 24 VDC, opto-decoupled

Technical Data

Expansions

PROFIBUS board VPB 20100	Coupler card for integration of DISOMAT T into a PROFIBUS system as slave; plugged onto main board DWT 100. No extra space required in rack.
DeviceNet board VCB 010	Coupler card for integration of DISOMAT T into a DeviceNet system; plugged onto main board DWT 100. No extra space required in rack.
Power supply	- DNT 300 for 230 V~, -15% +10% - DNT 310 for 115 V~, -15% +10% - 47 – 63 Hz, 70 VA each. One unit is capable of supplying up to six main boards DWT 100. Primary and secondary sides galvanically isolated and safety-separated (VDE 0160).
Explosion protection	Ex-protective circuitry DXB 100/102/103 for mounting of electrical equipment in Zone 1/21 (ATEX II 2G 2D). Board incl. front panel of same dimensions as main board DWT 100. Protected "intrinsically safe" for: - Load cell connection - Serial interface for secondary display - Analog output for secondary display - Binary input for two contacts (e.g. initiators) PTB 02 ATEX 2046 X ATTENTION: When analog output is connected in the hazardous area, the series resistors in barrier reduce the maximum external load by approx. 300 ohms.
Explosion-proof load cells (with safety barrier DXB 102)	1 – 8 Schenck RT load cells EEx ia IIC T4, or T6 PTB 02 ATEX 2092 / 2093 18.0 V with 1 load cell 15.5 V with 3 load cells 14.6 V with 4 load cells 12.9 V with 6 load cells 10.2 V with 8 load cells or max. 4 load cells with 350 ohms impedance, e.g. Schenck VBB PTB 02 ATEX 2091 Supply voltage: 10,4 V with 1 load cell 5,3 V with 3 load cells 4,3 V with 4 load cells Please ask us for data of other load cells (e.g. Flintec, Revere).
Options	Displays for analog output and serial interface, also integrated in device. ATTENTION: The use of the optional DISOMAT T display reduces the maximum admissible external load of the analog output by 250 ohms. This option cannot be combined with the analog output mounted in the hazardous area.

Variants	Ordering Number
DWT 100 DISOMAT T Weigh Transmitter, p.c. board including front panel	V 019323.B01
DWT 100 - D DISOMAT T Weigh Transmitter, p.c. board with front panel, complete with integral LED weight display	V 008566.B01
DWT 101 DISOMAT T Weigh Transmitter, Profibus expansion board on p.c. board, including front panel	D 707039.02
DFG 100 DISOMAT T in fieldbox DFG, for 24VDC supply	D 707043.01
DFG 100 - D DISOMAT T in fieldbox DFG, for 24VDC supply, complete with integral LED weight display	V 008558.B 01
DFG 101 DISOMAT T in fieldbox DFG, for 24VDC supply, complete with Profibus expansion board	D 707043.02
DFG 101 - D DISOMAT T in fieldbox DFG, for 24VDC supply, complete with Profibus expansion board and integral LED weight display	V 008560.B 01
DFG 110 DISOMAT T in fieldbox DFG, complete with transformer for 115/230VAC supply	707044.01
DFG 110 - D DISOMAT T in fieldbox DFG, complete with transformer for 115/230VAC supply and integral LED weight display	V 008559.B 01
DFG 111 DISOMAT T in fieldbox DFG, complete with transformer for 115/230VAC supply and Profibus expansion board	707044.02
DFG 111 - D DISOMAT T in fieldbox DFG, complete with transformer for 115/230VAC supply, Profibus expansion board and integral LED weight display	V 008561.B 01
Adapter cable for 1 x Profibus connection at the 19" rack rear wall (max. 5 possible in 19" rack)	K 006038.01
Adapter cable VSC 20205 for Profibus connection of 5 DISOMAT T to a bus cable (2 possible in 19" rack)	V 031075.B01

Hazardous Area Variants	Ordering Number
DXB 100 Ex-protective circuitry designed as p.c. board including front panel	707041.01
DFG 100E DISOMAT T in fieldbox DFG, for 24VDC supply, complete with Ex- protective circuitry	707043.04
DFG 100E - D DISOMAT T in fieldbox DFG, for 24VDC supply, complete with Ex- protective circuitry and integral LED weight display	V 008562.B 01
DFG 101E DISOMAT T in fieldbox DFG, for 24VDC supply, complete with Profibus expansion board and Ex- protective circuitry	707043.05
DFG 101E - D DISOMAT T in fieldbox DFG, for 24VDC supply, complete with Profibus expansion board, Ex- protective circuitry and integral LED weight display	V 008564.B 01
DFG 110E DISOMAT T in fieldbox DFG, complete with transformer for 115/230VAC supply and Ex-protective circuitry	707044.04
DFG 110E - D DISOMAT T in fieldbox DFG, complete with transformer for 115/230VAC supply, Ex-protective circuitry and integral LED weight display	V 008563.B 01
DFG 111E DISOMAT T in fieldbox DFG, complete with transformer for 115/230VAC supply, Profibus expansion board and Ex-protective circuitry	707044.05
DFG 111E - D DISOMAT T in fieldbox DFG, complete with transformer for 115/230VAC supply, Profibus expansion board, Ex-protective circuitry and integral weight display	V 008565.B 01
DISOPLAN T PC software for parameterisation of DISOMAT T, operable under WINDOWS 9x, ME, 2000, NT and XP.	D721017.02

Please ask us for further variants.

e.g.:

- DFG 100 – E02
- DFG 101 – E02
- DFG 100 – E21